

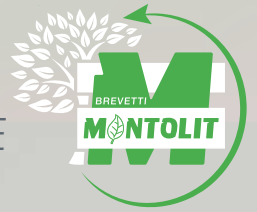

-  Attrezzature professionali per posatori
-  Professionelle Werkzeuge für den Fliesenleger
-  Outils Professionels pour Carreleurs

Catalogo generale | Gesamtkatalog | Catalogue général



for EARTH and PEOPLE



Brevetti Montolit è nata nel 1946 dalle geniali intuizioni del Cav. Montoli Vincenzo e non si è più fermata; da allora l'evoluzione è stata incessante. Pilastrì portanti dalla nascita sono: propensione all'innovazione, creatività e continua voglia di migliorarsi indispensabili per generare prodotti unici coperti da brevetti internazionali. Nel 2024 entra a far partedi un importante gruppo multindustriale svedese, nel 2026 celebra con orgoglio l'ottantesimo anniversario della fondazione.

*Brevetti Montolit wurde 1946 durch die brillanten Intuitionen von Cav. Montoli Vincenzo gegründet und hat sich seitdem unaufhörlich weiterentwickelt. Die wichtigsten Säulen seit der Gründung sind: Innovationssfreude, Kreativität und ständiger Verbesserungswille, die unabdingbar sind, um einzigartige Produkte zu schaffen, die durch internationale Patente geschützt sind. Im Jahr 2024 wird es Teil einer bedeutenden schwedischen Multiindustriegruppe; im Jahr 2026 feiert es stolz den achtzigsten Jahrestag seiner Gründung.*

*Brevetti Montolit est née en 1946 des intuitions brillantes de Vincenzo Montoli et la société connaît depuis lors une évolution constante. Les principes fondamentaux depuis sa création sont : la volonté d'innover, la créativité et le désir constant de s'améliorer, indispensables pour créer des produits uniques couverts par des brevets internationaux. En 2024, elle intègre un important groupe multi-industriel suédois; en 2026, elle célèbre avec fierté le quatre-vingtième anniversaire de sa fondation.*

## 2026 ITALICA

1974



1946

**NEW**

IT NOVITA'  
 DE NEUHEIT  
 FR NOUVEAUTÉ

pg. 02 > 03



IT Tagliapiastrelle manuali  
 DE Manuelle Fliesenschneider  
 FR Découpeuse à carreaux manuel

pg. 04 > 15

Ricambi | Ersatzteile | Pièces détachées

pg. 16 > 17

**300** PROJECT 300

IT Tecnologie per la lavorazione delle lastre ceramiche  
 DE Technologien zur Bearbeitung von Keramikplatten  
 FR Technologies de traitement des dalles en céramique

pg. 18 > 38



IT Movimentazione di grandi lastre  
 DE Handhabung von großer Platten  
 FR Manipulation de grandes dalles

pg. 20 > 27



IT Sistemi di taglio per il grande formato  
 DE Schneidesysteme für das Großformat  
 FR Systèmes de découpe pour grands formats

pg. 28 > 33



IT Ventose battenti per piastrelle e lastre  
 DE Elektrischer Vibrationssaugheber für Fliesen und Platten  
 FR Ventouse à levier avec percussions pour carreaux et dalles

pg. 34 > 35



IT Sistema di profilatura a secco  
 DE Trockenes Profilierungssystem  
 FR Système de profilage à sec

pg. 36 > 38



IT Attrezzature elettriche  
 DE Elektrische Ausrüstung  
 FR Équipement électrique

pg. 39 > 45



IT Attrezzature manuali per la posa  
 DE Manuelle Ausrüstung für das Verlegen von Fliesen  
 FR Équipement manuel pour la pose de carrelage

pg. 46 > 49



IT Tranciablocchetti / tagliategole  
 DE Gehweg-Plattenspalter / Dachziegel Handschneider  
 FR Découpeuse à dalles et à pavé / Découpeuse a tuiles

pg. 50 > 51

Ricambi | Ersatzteile | Pièces détachées

pg. 52 > 53



IT Lame circolari per legno  
 DE Kreissägeblätter für Holz  
 FR Lames circulaires pour le bois

pg. 54



IT Guida assistita per tagli perfetti  
 DE Support/Führung für perfekte Schnitte  
 FR Guidage assisté pour des coupes parfaites

pg. 55



IT Utensili diamantati DNA  
 DE "DNA" Diamant-Werkzeuge  
 FR Outils diamant "DNA"

pg. 56 > 68



IT Dischi diamantati  
 DE Diamanttrennscheiben  
 FR Disques diamantes

pg. 70 > 84



IT Foratura  
 DE Bohren  
 FR Perçage

pg. 85 > 96



IT Lavorazioni speciali  
 DE Spezielle Bearbeitungen  
 FR Outils pour travaux spéciaux

pg. 97 > 106



IT Espositori modulari  
 DE Ausstell-Module  
 FR Présentoirs modulaires

pg. 107 > 108

Condizioni di vendita | Verkaufsbedingungen | Conditions de vente

pg. 109



# NEUE Produkte



- IT Tagliapiastrelle manuali super professionali.
- DE Superprofessionelle manuelle Fliesenschneider.
- FR Coupe-carreaux manuel super professionnel.



pg. 4

## GECO e-power2

- IT Ventosa professionale a batteria.
- DE Professioneller batteriebetriebener Saugnapf.
- FR Ventouse à batterie professionnelle.



pg. 22

## GECONE JR

- IT Ventosa super professionale a batteria.
- DE Super professioneller batteriebetriebener Saugnapf.
- FR Ventouse à batterie super professionnelle.



pg. 23

## DUAL MINIGECO

- IT Kit doppia miniventosa a batteria.
- DE Batteriebetriebenes Doppel-Mini-Saugnapf-Set.
- FR Kit de double mini ventouse alimenté par batterie.



NEW 20/26

## MINI FLEXITILE

- IT Minimerigliatrice per piastrellisti.
- DE Mini-Winkelschleifer für Fliesenleger.
- FR Mini-meuleuse pour carreleurs.



NEW 20/26

## GRES LINEA

- IT Matita speciale per piastrellisti.
- DE Spezialstift für Fliesenleger.
- FR Crayon spécial pour carreleurs.



NEW 20/26

pg. 48

# NOUVEAUX produits

## CSS - ULTRATHIN

pg.  
70

- IT Dischi diamantati supersottili.
- DE Ultradünne Diamanttrennscheiben.
- FR Disques diamantés ultra-fins.



## MINI & MIDI - 50 & 76

pg.  
72

- IT Utensili diamantati di piccolo diametro (50/76mm).
- DE Diamantwerkzeuge mit kleinem Durchmesser (50/76 mm).
- FR Outils diamantés de petit diamètre (50/76 mm).



## TC-HD

pg.  
75

- IT Porcellanato alta densità.
- DE Feinsteinzeug mit hoher Dichte.
- FR Grès cérame haute densité.



## CPJ250

pg.  
76

- IT Taglio jolly ad umido.
- DE Nass-Gehrungsschnitt.
- FR Coupe en biseau à eau.



## FSBH

pg.  
88

- IT Foratura a secco.
- DE Trockenbohren.
- FR Perçage à sec.



Mondrillo **Black-H**

## FS-TI

**TOP  
SPEED**

pg.  
89

- IT Foratura a secco.
- DE Trockenbohren.
- FR Perçage à sec.



Mondrillo **Titanium Gold**

## FT-SB

pg.  
90

- IT Foratura a secco.
- DE Trockenbohren.
- FR Perçage à sec.



Killer Gres **Black**

## FT-S

**TOP  
LIFE**

pg.  
91

- IT Foratura a secco.
- DE Trockenbohren.
- FR Perçage à sec.



Killer Gres **Red**



# MASTERPIUMA

Serie **ITALICA**

*... the Team:*



Art. 63P5IT  
63 cm



Art. 81P5IT  
81 cm



Art. 101P5IT  
101 cm

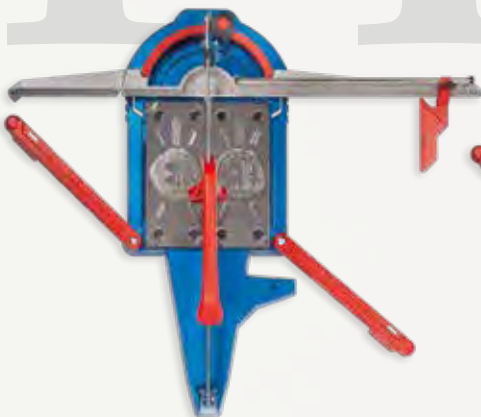

A red banner containing a video player with a 'Play' button, a QR code, and two QR codes. The video player shows a close-up of the tool's blade. The QR codes are for more information.

Tagliapiastrelle manuali SUPER PROFESSIONALI  
*SUPERPROFESSIONELLE manuelle Fliesenschneider*  
*Coupe-carreaux manuel SUPER PROFESSIONNEL*



Art. 131P5IT  
131 cm

Art. 161P5IT  
161 cm

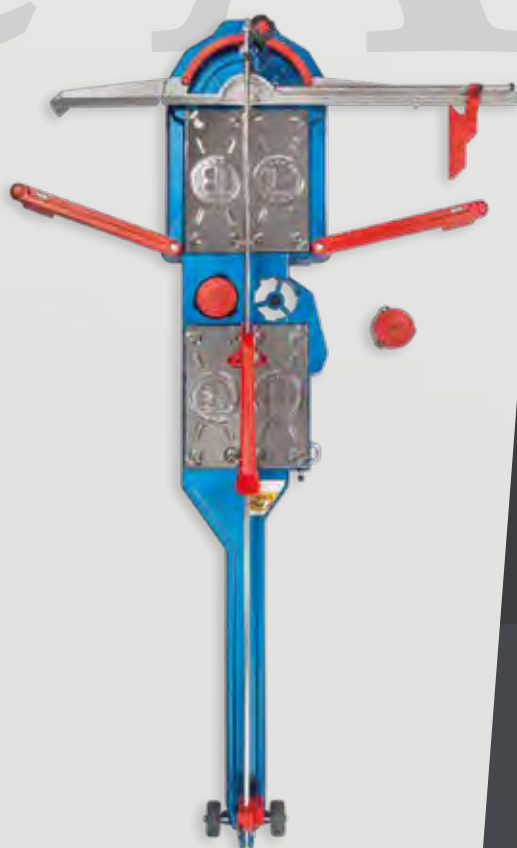
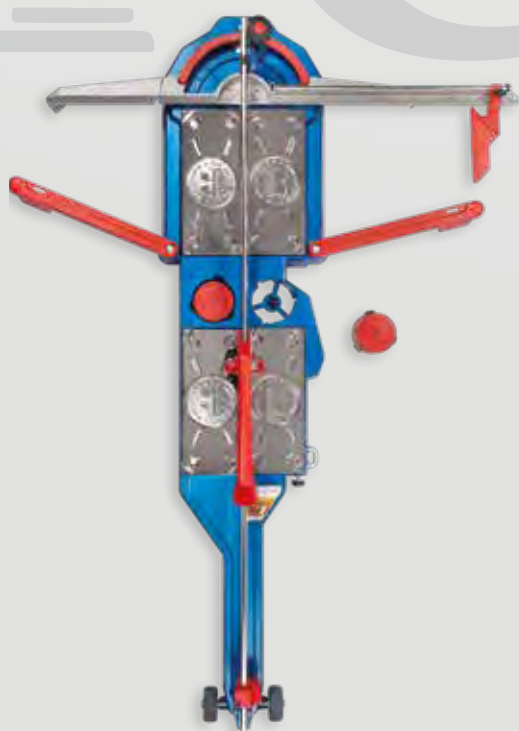



# MASTERPIUMA

Serie **ITALICA**



- Squadra +/- 45° con numerazione incisa laser, precisa e indelebile
- Winkel +/- 45° mit präziser und unauslöschlicher Lasernummerierung
- Équerre +/- 45° avec graduation gravée au laser précise et indélébile



- Portarotelle in alluminio con indicatori di forza e massima scorrevolezza senza compromessi
- Rädchenhalter aus Aluminium mit Kraftanzeige und kompromissloser Laufruhe
- Porte-molettes en aluminium avec indicateurs de force et fluidité maximale sans compromis

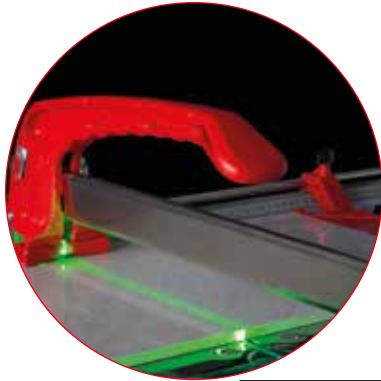

- \* Laser di puntamento mobile: precisione visiva totale
- \* Beweglicher Ziel-Laser: absolute visuelle Präzision
- \* Laser de pointage mobile: précision visuelle totale



- \* Baseboard (controsquadra) integrato
- \* Integriertes Baseboard (Anschlagleiste)
- \* Baseboard (contre-équerre) intégré



- \* Di serie solo nei modelli 131 & 161
- \* Serienmäßig nur bei den Modellen 131 & 161.
- \* De série uniquement sur les modèles 131 & 161.



Punti importanti  
Wichtige Punkte  
Points importants



- Supporti laterali in alluminio
- Seitenstützen aus Aluminium
- Supports latéraux en aluminium

- Squadretta di riferimento in alluminio da 17 cm, ribaltabile
- 17 cm lange Winkelstütze aus Aluminium
- Butée d'équerre en aluminium de 17 cm









- \* ATLAS integrati: sempre pronti, sempre efficaci
- \* Integrierte ATLAS-Systeme, immer einsatzbereit, immer effektiv
- \* ATLAS intégrés, toujours prêts, toujours efficaces

- Doppio sistema di spacco con mirino brevettato
- Doppeltes Spaltsystem mit patentierter Anzeige
- Double système de fissuration avec viseur brevété







- Rotella in titanio Ø 18 mm con cuscinetto integrato
- Titanrad Ø 18 mm mit integriertem Lager.
- Molette en titane Ø 18 mm avec roulement intégré.









	Art.			63P5IT	81P5IT	101P5IT	131P5IT	161P5IT
 TITANIUM	248T	S/12		✓	✓	✓	✓	✓
	501P5IT	S/1		✓				
	502P5IT	S/1			✓	✓	✓	✓
	507	B/1		✓	✓	✓	✓	✓
	515-5	B/1		✓	✓	✓	✓	✓
	428P2	S/1		✓	✓	✓	✓	✓
	456P5	S/1		✓				
	457P5	S/1			✓	✓	✓	✓
	458P5	S/1		✓				
	459P5	S/1			✓	✓	✓	✓
	418P	S/1		✓				
	419P5IT	S/1			✓	✓	✓	✓
	516P5	S/1		✓	✓	✓	✓	✓
	281	S/1		✓				
	281IT	S/1			✓	✓	✓	✓
	440P2	S/1		✓	✓	✓	✓	✓

Art. <b>63P5IT</b>		 <b>63 cm (24,5 inch)</b>			
					
cm	inch	max cm	max inch	kg	C/1
44 x 44	17 x 17	2	3/4	12	C/1

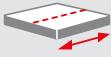







Art. <b>81P5IT</b>		 <b>81 cm (32 inch)</b>			
					
cm	inch	max cm	max inch	kg	C/1
57 x 57	22,5 x 22,5	2	3/4	16	C/1









Art. <b>101P5IT</b>		 <b>101 cm (40 inch)</b>			
					
cm	inch	max cm	max inch	kg	C/1
71 x 71	28 x 28	2	3/4	18	C/1



Art. <b>131P5IT</b>		 <b>131 cm (51,5 inch)</b>			
					
cm	inch	max cm	max inch	kg	C/1
92 x 92	36,5 x 36,5	2	3/4	23	C/1



Atlas, Baseboard e CutLine Laser inclusi  
Atlas, Baseboard und CutLine Laser inklusive  
Atlas, Baseboard et Laser CutLine inclus

Art. <b>161P5IT</b>		 <b>161 cm (63,5 inch)</b>			
					
cm	inch	max cm	max inch	kg	C/1
113 x 113	44,5 x 44,5	2	3/4	27	C/1



Atlas, Baseboard e CutLine Laser inclusi  
Atlas, Baseboard und CutLine Laser inklusive  
Atlas, Baseboard et Laser CutLine inclus

\*Mod. "inch" - Su richiesta - Auf Anfrage - Sur demande

# MOSAKIT

Art. 58

- IT Tappetino in gomma per mosaici, piastrelle in vetro, delicate e sottili (3mm).
- DE Gummi-Matte für Mosaikfliesen, Glas, zerbrechlichen und dünne Fliesen (3mm).
- FR Tapis en caoutchouc pour carreaux de mosaïque, du verre et ducarrelage fin et délicat (3mm).



# BASEBOARD

Art. 64

- IT Riferimento aggiuntivo per grandi formati ideale per il taglio di listelli e di battiscopa.
- DE Zusätzlicher Bezugspunkt für große Formate, ideal zum Zuschneiden von Sockelleisten.
- FR Référence supplémentaire pour les grandes tailles idéal pour couper bandes et plinthes.

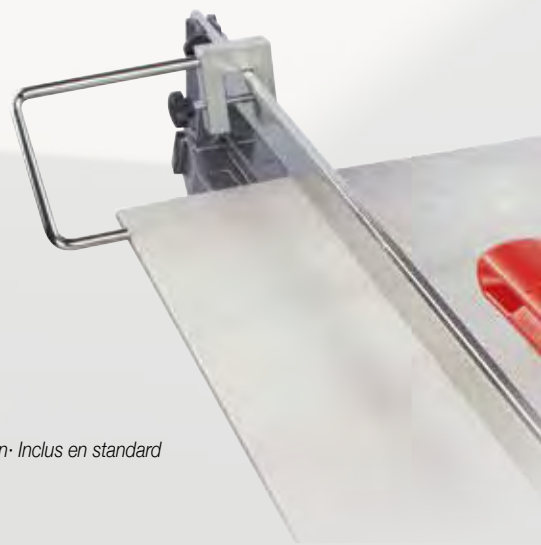
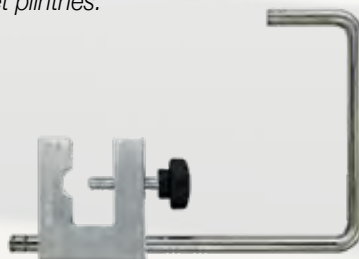

\* 131 & 161 P5 ITALICA: Di serie · Im Standardumfang enthalten · Inclus en standard

# VERTIGO

Art. VERTIGO2

- IT Supporto per tagliapiastrelle manuali. Agevola il taglio in verticale delle piastrelle di grande formato.
- DE Support für manuelle Fliesenschneider. Erleichtert vertikale Schnitte von großformat Fliesen.
- FR Support pour decoupeuse manuelle. Facilite la coupe verticale de carreaux de grand format.



# ATLAS



Art. ATLAS

- IT Sostegno elastico con doppia regolazione (altezza e peso) per piastrelle di grandi dimensioni utilizzabile con ogni tipo di tagliapiastrelle manuale.
- DE Verstellbare elastische Unterlage für große Fliesen. Kann mit jedem manuellen Fliesenschneider verwendet werden.
- FR Support élastique réglable pour grands carreaux. Peut être utilisé avec n'importe quel type de coupe-carreaux manuel.

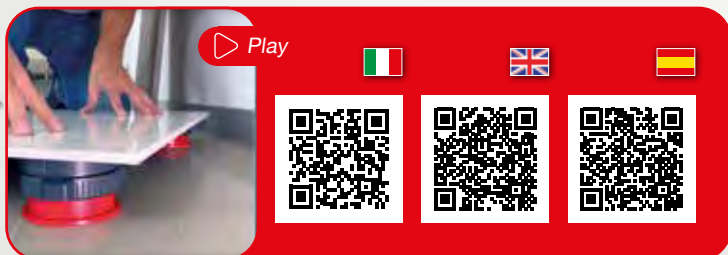

# CUTLINEA LASER



Art. LCL

- IT \*Indicatore laser linea di incisione per tagliapiastrelle manuali **Masterpiuma**.
- DE \*Lasermarkierungslinienanzeiger für **Masterpiuma** manuelle Fliesenschneider
- FR \*Indicateur de ligne de marquage laser pour coupe-carreaux manuels **Masterpiuma**.

\*131 & 161 P5 ITALICA: Di serie · Im Standardumfang enthalten · Inclus en standard



# CARAPAX



Art. CARAPAX

- IT Protezione elastica per tagliapiastrelle **Masterpiuma P5**.
- DE Elastischer Schutz für Fliesenschneider **Masterpiuma P5**.
- FR Protection élastique pour coupe-carreaux **Masterpiuma P5**.



# MASTERPIUMA EVOLUTION 3 - serie P3

Art. 52P3

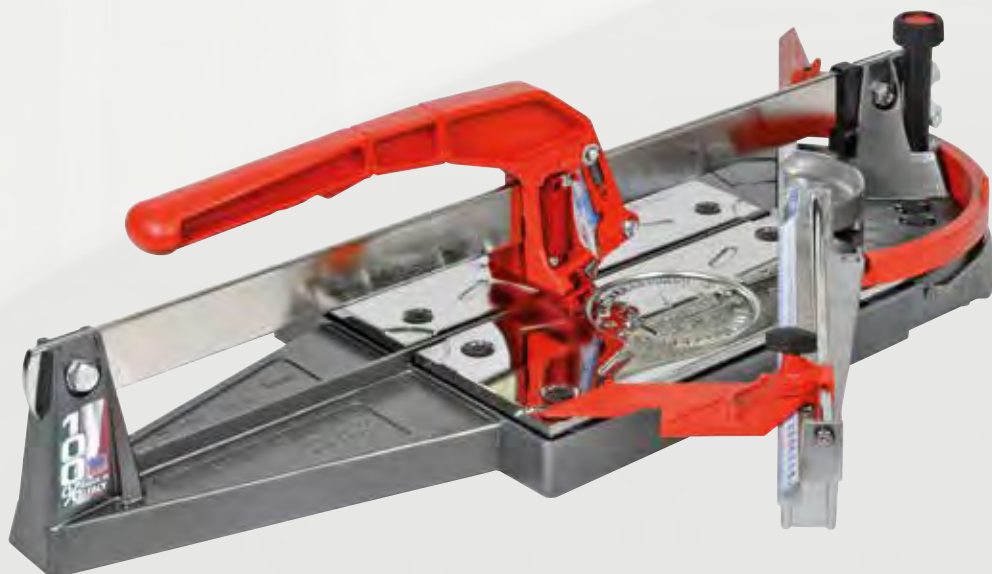

## F.A.Q.

**IT** Qual è il modo migliore per utilizzare la tagliapiastrelle Masterpiuma?

**DE** Wie kann ich den Masterpiuma Fliesenschneider am besten verwenden?

**FR** Quelle est la meilleure façon d'utiliser le coupe-carreaux Masterpiuma ?

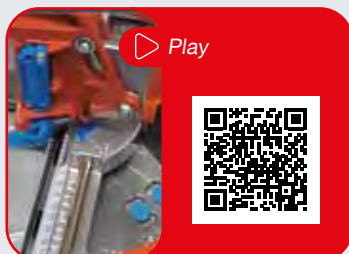

**IT** Come funziona la tagliapiastrelle Masterpiuma su piastrelle con superficie irregolare e strutturata?

**DE** Wie funktioniert der Masterpiuma Fliesenschneider bei Fliesen mit unebenen und strukturierten Oberflächen?

**FR** Comment le coupe-carreaux Masterpiuma fonctionne-t-il sur les carreaux à surface irrégulière et texturée ?

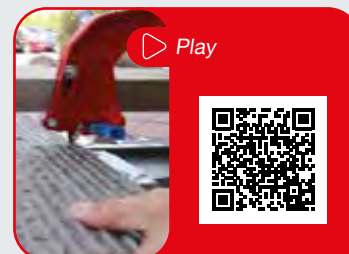

Art.							kg	
	cm	inch	cm	inch	max cm	max inch		
44P3	44	17	31 x 31	12 x 12	2	3/4	7,7	C/1
52P3	52	20	37 x 37	14 x 14	2	3/4	8,2	C/1
63P3	63	25	44 x 44	17 x 17	2	3/4	9,5	C/1
75P3	75	29	53 x 53	21 x 21	2	3/4	11,8	C/1
93P3	93	36	66 x 66	26 x 26	2	3/4	13,0	C/1
125P3	125	49	88 x 88	34,5 x 34,5	2	3/4	24,0	C/1
155P3	155	61	109 x 109	43 x 43	2	3/4	33,0	C/1

Accessori | Zubehör | Accessoires

## MOSAKIT

pg.  
10

Art. 58



**IT** Tappetino in gomma per mosaici, piastrelle in vetro, delicate e sottili (3mm).

**DE** Gummi-Matte für Mosaikfliesen, Glas, zerbrechlichen und dünne Fliesen (3mm).

**FR** Tapis en caoutchouc pour carreaux de mosaïque, du verre et ducarrelage fin et délicat (3mm).

## BASEBOARD

pg.  
10

Art. 64



**IT** Riferimento aggiuntivo per grandi formati ideale per il taglio di listelli e di battiscopa.





**DE** Zusätzlicher Bezugspunkt für große Formate, ideal zum Zuschneiden von Sockelleisten.

**FR** Référence supplémentaire pour les grandes tailles idéal pour couper bandes et plinthes.

# PIUMA BASIC - serie BP



Art. 63PB

Art.								
	cm	inch	cm	inch	max cm	max inch		
63BP	63	25	44 x 44	17 x 17	2	3/4	8,0	C/1
75BP	75	29	53 x 53	21 x 21	2	3/4	9,0	C/1
93BP	93	36	66 x 66	26 x 26	2	3/4	10,0	C/1
125BP	125	49	88 x 88	34,5 x 34,5	2	3/4	20,0	C/1

## CARAPAX



Art. CARAPAX



- IT** Protezione elastica per tagliapiastrelle.
- DE** Elastischer Schutz für Fliesenschneider.
- FR** Protection élastique pour coupe-carreaux.

## PIEDONE

Art. 449P



- IT** Sistema di spacco supplementare.
- DE** Zusätzliches Trennsystem.
- FR** Système de fissuration supplémentaire.

# MINIMONTOLIT 2

Minimontolit Evolution 2 è una tagliapiastrelle di piccole dimensioni, progettata appositamente per gli utenti fai da te e per lavori meno complicati con piastrelle standard. Questa gamma di macchine consente di tagliare piastrelle di diverso spessore (0-20 mm) e con angoli variabili (0-60°) senza alcuna regolazione.





Der Minimontolit Evolution 2 ist ein kleiner Fliesenschneider, der speziell für Heimwerker und für weniger komplizierte Arbeiten mit Standardfliesen entwickelt wurde. Mit diesem Maschinentyp können Fliesen unterschiedlicher Dicke (0-20 mm) und mit variablen Winkeln (0-60°) ohne Anpassung geschnitten werden.

Le Minimontolit Evolution 2 est un petit coupe-carreaux spécialement conçu pour les bricoleurs et pour les travaux moins compliqués avec des carreaux standards. Cette gamme de machines permet de couper des carreaux de différentes épaisseurs (0-20 mm) et avec des angles variables (0-60°) sans ajustement.



Art. 26A2



Art.								
	cm	inch	cm	inch	max cm	max inch		
24	22	8	15 x 15	6 x 6	1,5	1/2	0,6	C/6
26A2	36	14	25 x 25	10 x 10	2	3/4	2,8	C/6
43A2	45	18	31 x 31	12 x 12	2	3/4	3,5	C/2

# MINIPIUMA

Questa mini tagliapiastrelle è consigliata sia ai piastrellisti professionisti che agli amanti del fai da te. È particolarmente adatta per l'installazione di piastrelle in grès porcellanato e mosaici in spazi ristretti, dove vengono comunemente installate piastrelle di piccole dimensioni, come cucine e bagni.





*Dieser Mini-Fliesenschneider wird sowohl für professionelle Fliesenleger als auch für Heimwerker empfohlen. Er eignet sich besonders für die Verlegung von Feinsteinzeugfliesen und Mosaik in Räumen, in denen häufig kleine Fliesen verlegt werden, wie z. B. in Küchen und Bädern.*



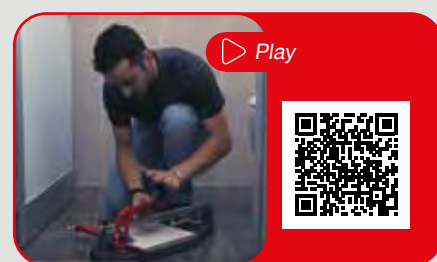















*Ce mini-coupe-carreaux est recommandé pour les carreleurs professionnels et les bricoleurs. Il est particulièrement adapté à la pose de carreaux de porcelaine et de mosaïques dans les espaces confinés, où les petits carreaux sont couramment installés, tels que les cuisines et les salles de bains.*



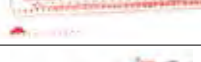

















Art. 43PB



Art.								
	cm	inch	cm	inch	max cm	max inch		
26PBox	36	14	25 x 25	10 x 10	2	3/4	5,8	C/2
43PBox	45	18	31 x 31	12 x 12	2	3/4	6,3	C/2

				 <p>pg. 14</p>							 <p>pg. 15</p>				 <p>pg. 13</p>				
				MINIMONTOLIT							MINIPIUMA				PIUMA BASIC				
	Art.			24	26	26A	26A2	43	43A	43A2	26P	26PB	43P	43PB	63PB	75PB	93PB	125PB	155PB
	245	S/12		✓	✓	✓	✓	✓	✓	✓	✓	✓	✓	✓	✓	✓	✓	✓	✓
 TITANIUM	245T	S/12		✓	✓	✓	✓	✓	✓	✓	✓	✓	✓	✓	✓	✓	✓	✓	✓
	445BP	S/1													✓	✓	✓		
	445BP12	S/1																✓	✓
	264P	S/1									✓	✓	✓	✓					
	264	S/1			✓	✓		✓	✓										
	264B	S/1					✓			✓									
	259	B/1		✓															
	446P	B/1													✓	✓	✓	✓	✓
	318	B/1			✓	✓	✓	✓	✓	✓					✓	✓	✓	✓	✓
	448P	B/1									✓	✓	✓	✓					
	429P-EVO	S/1									✓	✓	✓	✓					
	428T	S/1													✓	✓	✓	✓	✓
	460P	B/1													✓	✓	✓	✓	✓
	458P	B/1									✓	✓	✓	✓					
	452P	S/1									✓	✓	✓	✓					
	454P	S/1													✓	✓	✓		
	456P	S/1																✓	✓
	418P	S/1													✓	✓	✓	✓	✓
	415P	S/1																✓	✓
	280	S/1				✓	✓		✓	✓									
	280P	S/1									✓	✓	✓	✓					
	277	B/1		✓	✓	✓	✓	✓	✓	✓									
	277P	B/1									✓	✓	✓	✓					
	281	S/1													✓	✓	✓		
	281H	S/1																✓	✓
	440P2	S/1													✓	✓	✓	✓	✓

												 pg. 12													
				MASTERPIUMA P2								MASTERPIUMA P3								MASTERPIUMA P5					
	Art.			44P2	52P2	63P2	75P2	93P2	125P2	155P2	44P3	52P3	63P3	75P3	93P3	125P3	155P3	63P5	63P5XL	75P5	93P5	131P5	161P5		
	245	S/12		✓	✓	✓	✓	✓	✓	✓	✓	✓	✓	✓	✓	✓	✓	✓	✓	✓	✓	✓	✓	✓	
 TITANIUM	245T	S/12		✓	✓	✓	✓	✓	✓	✓	✓	✓	✓	✓	✓	✓	✓	✓	✓	✓	✓	✓	✓	✓	
	505	S/1		✓	✓	✓					✓	✓	✓												
	506	S/1					✓	✓	✓	✓				✓	✓	✓	✓								
	501P5IT	S/1																✓	✓						
	502P5IT	S/1																		✓	✓	✓	✓	✓	
	507	B/1									✓	✓	✓	✓	✓	✓	✓	✓	✓	✓	✓	✓	✓		
	446P	B/1		✓	✓	✓	✓	✓	✓	✓															
	318	B/1		✓	✓	✓	✓	✓	✓	✓															
	515-5	B/1		✓	✓	✓	✓	✓	✓	✓	✓	✓	✓	✓	✓	✓	✓	✓	✓	✓	✓	✓	✓		
	428P2	S/1		✓	✓	✓	✓	✓	✓	✓	✓	✓	✓	✓	✓	✓	✓	✓	✓	✓	✓	✓	✓		
	455P2	S/1		✓	✓						✓	✓													
	456P2	S/1				✓	✓	✓					✓	✓	✓										
	457P2	S/1							✓	✓						✓	✓								
	456P5	S/1																✓	✓	✓	✓				
	457P5	S/1																				✓	✓	✓	
	459P	S/1		✓	✓	✓	✓	✓	✓	✓	✓	✓	✓	✓	✓	✓	✓								
	458P5	S/1																✓	✓	✓	✓				
	459P5	S/1																				✓	✓	✓	
	418P	S/1		✓	✓	✓	✓	✓	✓	✓	✓	✓	✓	✓	✓	✓	✓		✓	✓	✓	✓	✓	✓	
	415P	S/1							✓	✓						✓	✓								
	418P5	S/1																✓							
	519P5	S/1																✓							
	516P5	S/1																	✓	✓	✓	✓	✓		
	480P2	B/1		✓	✓						✓	✓													
	481P2	B/1				✓	✓	✓	✓	✓			✓	✓	✓	✓									
	480P5	B/1																✓							
	481P5	B/1																	✓	✓	✓	✓	✓	✓	
	281	S/1		✓	✓	✓	✓	✓			✓	✓	✓	✓	✓			✓	✓	✓	✓				
	281H	S/1							✓	✓						✓	✓					✓	✓		
	440P2	S/1		✓	✓	✓	✓	✓	✓	✓	✓	✓	✓	✓	✓	✓	✓	✓	✓	✓	✓	✓	✓		

# 300 **PROJECT 300**

Tecnologie per la lavorazione delle lastre ceramiche  
*Technologien für die Verarbeitung von Keramikfliesen*  
*Technologies de traitement des dalles céramiques*

IT

## **Sistema per la movimentazione e la lavorazione di piastrelle giganti by Montolit**

Le caratteristiche principali da tenere in considerazione nella posa di queste piastrelle sono: dimensione, flessibilità, fragilità e peso.

Il PROGETTO 300 by Montolit comprende una linea di attrezzature espressamente progettata per permettere di affrontare la posa delle lastre con facilità e risultati eccellenti.

FR

## **Système pour la manutention et l'usage de carreaux grand format by Montolit.**

Les principales caractéristiques qu'il faut considérer durant la pose de ces carreaux sont: dimension, flexibilité, fragilité et poids.

PROGETTO 300 by Montolit comprend une ligne d'équipements spécialement conçue pour permettre d'affronter facilement la pose de carreaux et d'obtenir des résultats excellents.

DE

## **System für den Transport und die Verarbeitung von großformatigen Platten by Montolit.**

Die wesentlichen Merkmale für die Verlegung dieser Platten sind: Ausmaß, Flexibilität, Empfindlichkeit und Gewicht.

Das PROJEKT 300 by Montolit umfasst eine Linie eigens entworfener Werkzeuge, um die Verlegung der Platten einfacher und mit hervorragendem Ergebnis durchzuführen.

Un sistema completo  
*Ein komplettes System*  
*Un système complet*

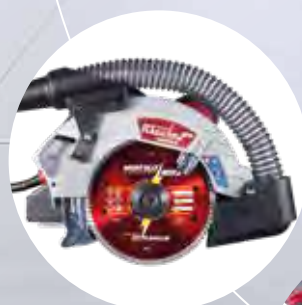

# GECO ROBOT

IT Sistema robotizzato a batteria per il sollevamento e la movimentazione delle lastre.  
 DE Batteriebetriebenes Robotersystem zum Heben und Handhaben von Platten.  
 FR Système robotique alimenté par batterie pour le levage et la manutention de dalles.



**SPECIAL RED RUBBER  
NO STAMP**

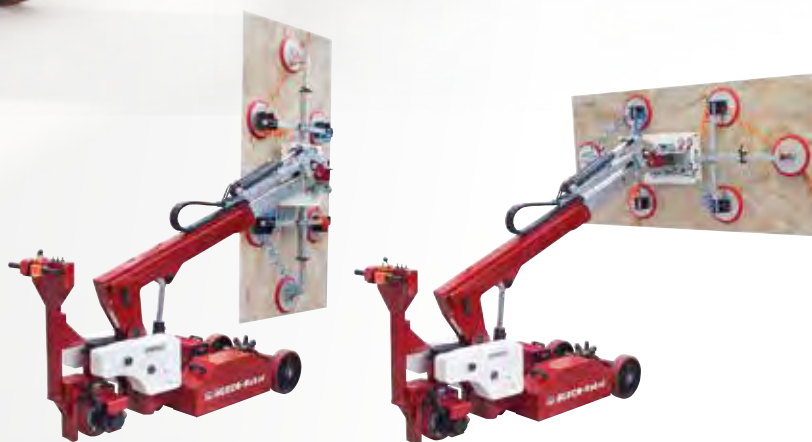
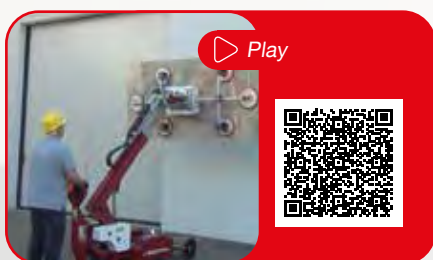

mt.	kg	mm	kg	kg		
3,25	190 / 485	6 x Ø 300	900	20 x 14 pz	2 x 12V-80A	105x225x130(h) 120kg



# GOAL

- IT Carrello polifunzionale per il trasporto e la lavorazione di lastre.
- DE Mehrzweck Drehgestell für den Transport und die Verarbeitung von großen Fliesen.
- FR Chariot multi-usage pour le transport et traitement des grands carreaux.







**Pos. 1**  
Movimentazione  
Transport  
Manutention



**Pos. 2**  
Stesura adesivo  
Aufbringen des Klebers  
Pose adhésif







Art.	 cm	 kg	 kg	 BOX
300-85-EVO	150 x 70 x 150 (h)	28	260	C/1

# LIFTERS

- IT Sollevatori livellanti.
- DE Hebe- und Nivelliersystem.
- FR Systeme de soulevement et nivellement.





Art.	 h	 kg	 kg	 BOX	
LIFTERS	Set 2 pcs.	30	2,95	25	S/1



# CORNER

- IT Paraspigoli.
- DE Kantenschutz.
- FR Protecteurs d'angle.

Art.		Stück/Pièces	 BOX
	mm      inch		
300-95-04	3 ÷ 4      1/8 ÷ 5/32	Set 4	B/1
300-95-06	5 ÷ 6      3/16 ÷ 1/4	Set 4	B/1
300-95-10	8 ÷ 10     5/16 ÷ 3/8	Set 4	B/1
300-95-12	11 ÷ 12    7/16 ÷ 1/2	Set 4	B/1



# GECO e-power2

**NEW**

CE

**SPECIAL RED RUBBER  
NO STAMP**

**NO STOP OPERATION  
16  
HOURS**

**ELECTRONIC  
CONTROL DISPLAY**

**IP54**

IT Ventosa professionale a batteria.  
DE Professioneller batteriebetriebener Saugnapf.  
FR Ventouse à batterie professionnelle.

Display di controllo  
Bedienanzeige  
Affichage de contrôle

Pulsante On/Off  
Schalter On/Off  
Interrupteur On/Off

Pulsante di rilascio dell'aria  
Taste für Luftauslass  
Bouton d'évacuation de l'air



Ricarica USB Type-C  
Nachladen USB-Typ-C  
Recharge USB type-C

Art.						
GECO E-POWER2	3,7VDC -LI-ion 1,5 Ah	USB · Type-C	3 h	200 mm	1,17 kg	S/1

# VT-300

IT Doppia ventosa per avvicinare e allineare le lastre.  
DE Doppelter Saugnapf zum Annähern und Ausrichten von großformatigen Fliesen.  
FR Double ventouse pour approcher et aligner les grands carreaux.

**SPECIAL RED RUBBER  
NO STAMP**



Art.		
VT-300	150 mm	C/1



# GECONE JR e-power



- IT Ventosa super professionale a batteria.
- DE Super professioneller batteriebetriebener Saugnapf.
- FR Ventouse à batterie super professionnelle.



Display di controllo  
Bedienanzeige  
Affichage de contrôle

Pulsante On/Off  
Schalter On/Off  
Interrupteur On/Off

Pulsante di rilascio dell'aria  
Taste für Luftauslass  
Bouton d'évacuation de l'air



Ricarica USB Type-C  
Nachladen USB-Typ-C  
Recharge USB type-C



Art.						
			h	mm	kg	BOX
GECONE JR	12VDC -Li-ion - 2 Ah	USB · Type-C	3	270 x 15,5	1,15	S/1



Anelli ventosa intercambiabili  
Austauschbare Saugnapfiringe  
Anneaux à ventouse interchangeables

**SPECIAL RED RUBBER  
NO STAMP**

pg. 52 → Ricambi  
Ersatzteile  
Pièces détachées

# LIFT e-power



- IT Barra singola con due ventose.
- DE Einzelne Stange mit zwei Saugnapfen.
- ES Barre simple avec deux ventouses.



Ventosa facilmente estraibile.  
Leicht herausnehmbare Saugglocke.  
Ventouse facilement amovible.

Pieghevole.  
Zusammenlegbar.  
Pliant.

Ventosa elettronica a batteria.  
Batteriebetriebener elektronischer Saugnapf.  
Ventouse électronique alimentée par batterie.

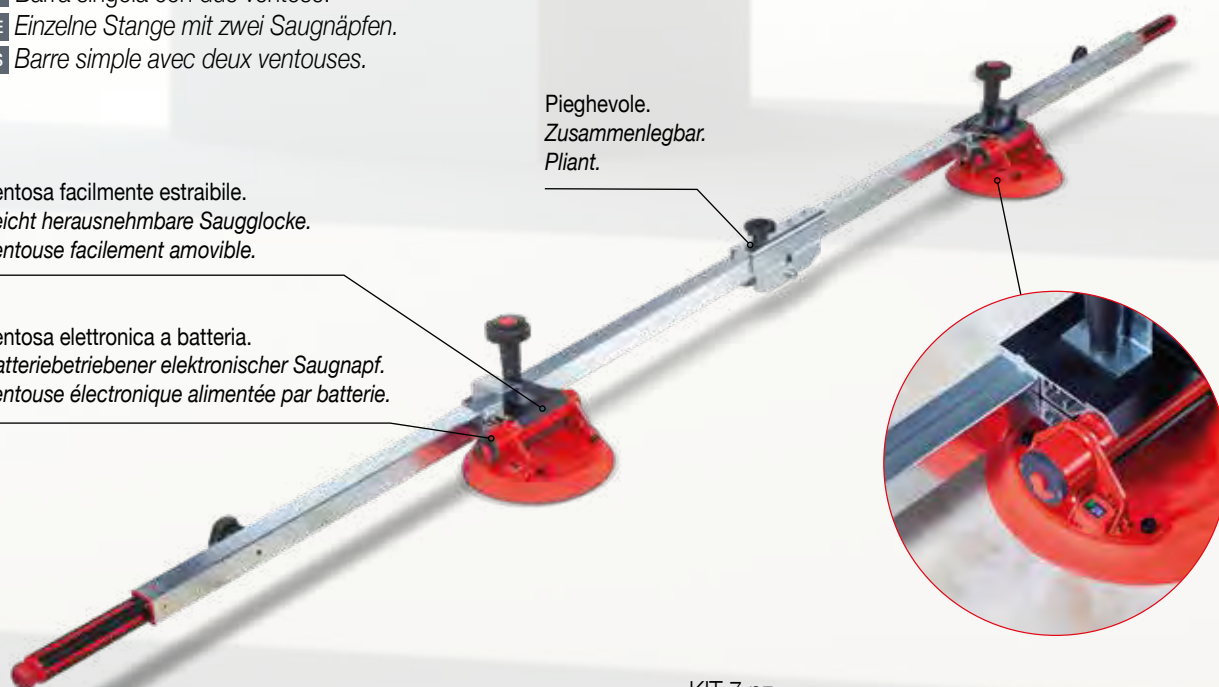

KIT 7 pz.

Art.	kg	BOX
LIFT e-power	10	C/1



## OPTIONALS Superlift e-power

Art. SUPERLIFT e-power-01

- IT Ventosa Extra - 2 pz.
- DE Extra Saugnapf - 2 Stk.
- FR Ventouse extra - 2 pcs.

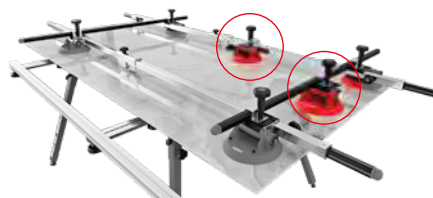

Art. SUPERLIFT e-power-02

- IT Sistema di sicurezza per lastre corrugate - 4 pz.
- DE Support für strukturierte Oberflächen - 4 Stk.
- FR Crochets de sécurité supplémentaires pour les carreaux rugueuses - 4 pcs.

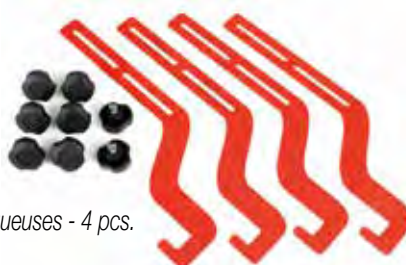

# SUPERLIFT e-power



IT Sistema modulare per la movimentazione di grandi lastre.  
 DE Modulares Baukastensystem für großformatige Fliesen.  
 FR Système modulaire de manipulation des grands carreaux.

SPECIAL RED RUBBER  
NO STAMP

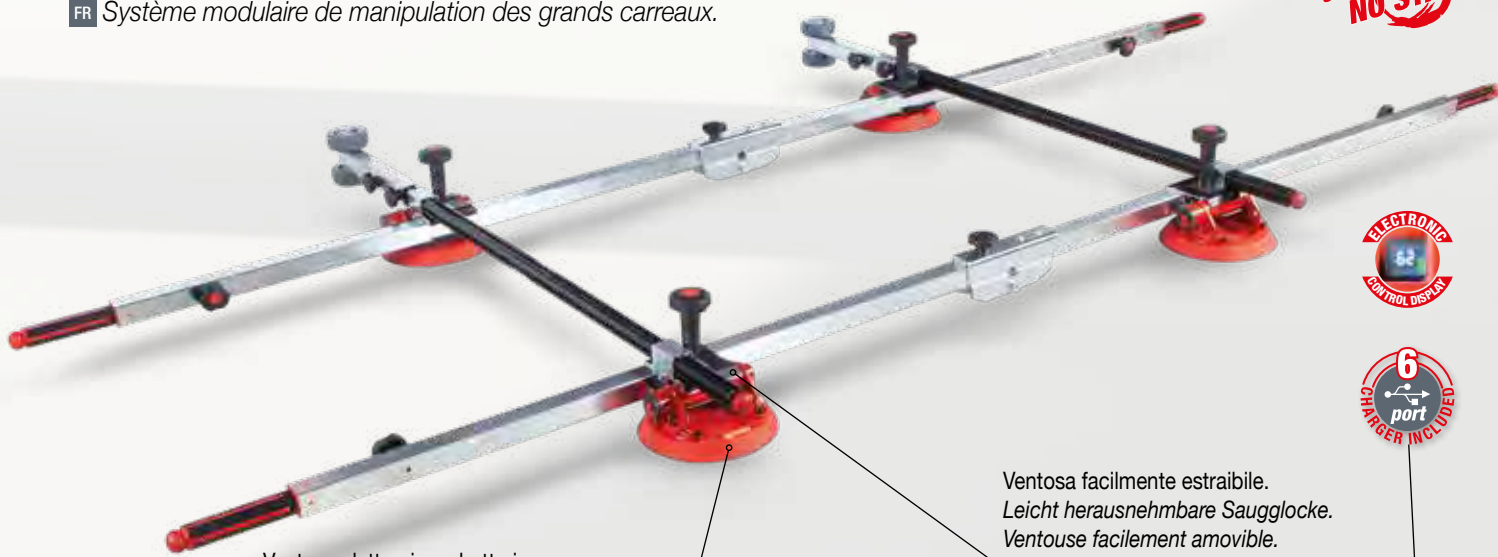

Ventosa elettronica a batteria.  
 Batteriebetriebener elektronischer Saugnapf.  
 Ventouse électronique alimentée par batterie.

Ventosa facilmente estraibile.  
 Leicht herausnehmbare Saugglocke.  
 Ventouse facilement amovible.

KIT 20 pz.



Pieghevole.  
 Zusammenlegbar.  
 Pliant.

Art.



Art.	kg	BOX
SUPERLIFT e-power	26	C/1

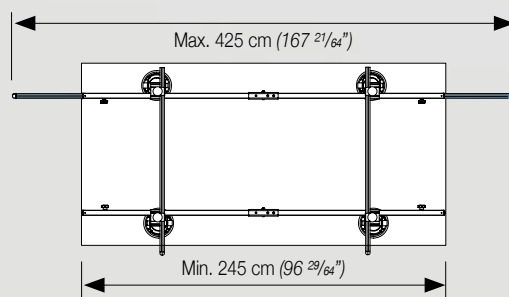

Play

## OPTIONAL

Art. 300-20-PLUS

- IT Kit prolunga per TABLE-ONE.
- DE Extensionskit für TABLE-ONE.
- FR Kit d'extension pour TABLE-ONE.

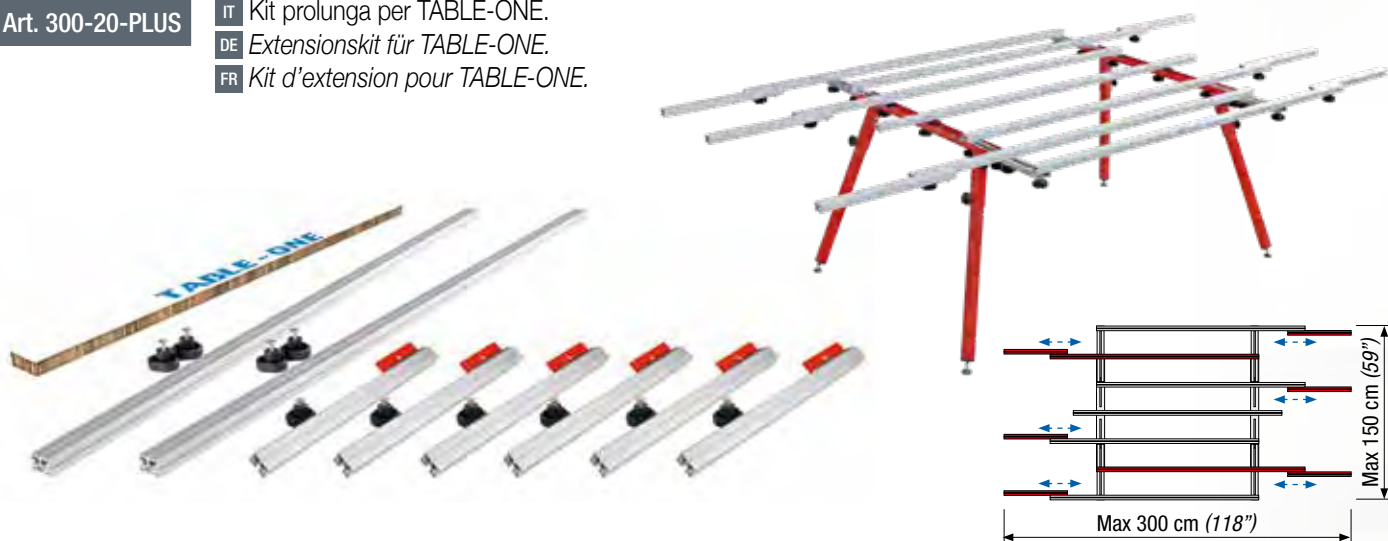

## OPTIONAL

Art. 300-25

- IT Barra di alluminio extra.
- DE Zusätzliches Aluminiumprofil.
- FR Barre supplémentaire en aluminium.

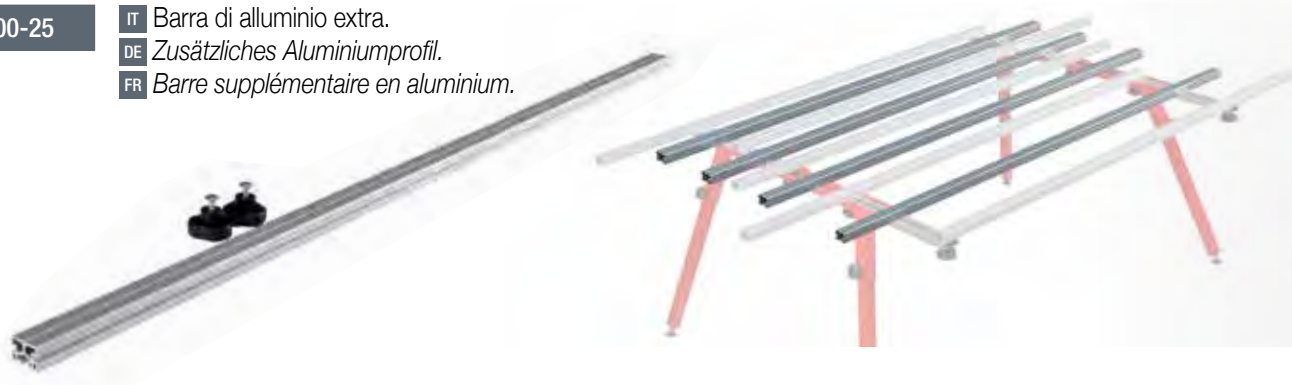

## Due banchi combinati | Zwei Tische kombiniert | Deux tables combinées



# TABLE-ONE



IT Banco da lavoro.  
 DE Arbeitstisch.  
 FR Table de travail.

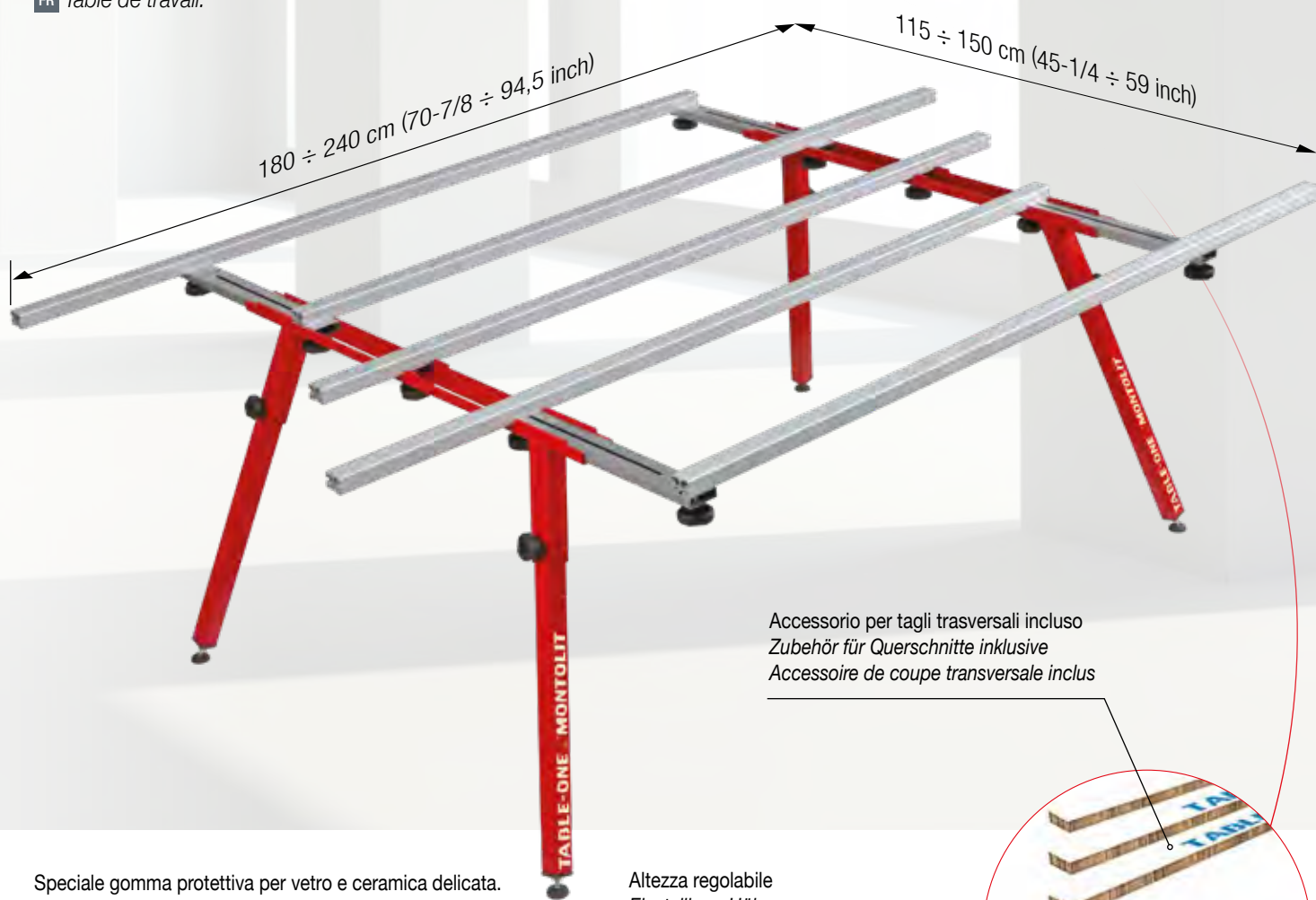

Accessorio per tagli trasversali incluso  
 Zubehör für Querschnitte inklusive  
 Accessoire de coupe transversale inclus

Speciale gomma protettiva per vetro e ceramica delicata.  
 Spezieller Schutzgummi für Glas und empfindliche Keramiken.  
 Caoutchouc de protection spécial pour le verre et les céramiques délicates.

Altezza regolabile  
 Einstellbare Höhe  
 Hauteur réglable

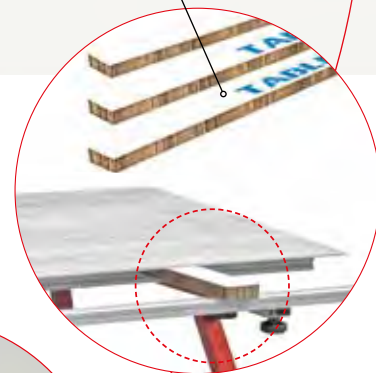
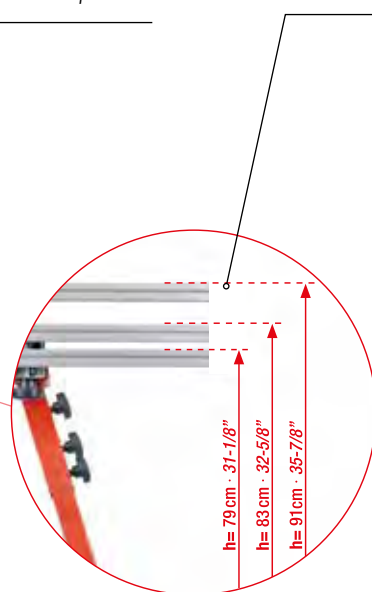
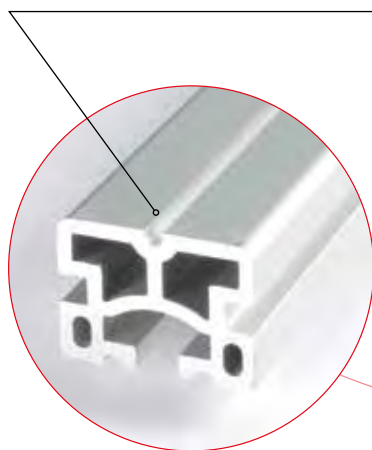

Lunghezza e larghezza regolabili  
 Länge und Breite einstellbar  
 Longueur et largeur réglables

Art.	MIN		MAX		kg	BOX
	cm	inch	cm	inch		
300-20	115 x 180	45-1/4 x 70-7/8	150 x 240	59 x 94-1/2	34	C/1

# FL3 FLASH LINE



La rivoluzione del taglio sul grande formato  
*Die Revolution im Großformat Schneiden*  
*La révolution de la découpe grand format*

Progettata in collaborazione con il Politecnico dell'Università di Milano, permette il taglio manuale di lastre in grès porcellanato di grandi dimensioni fino ad 1 cm di spessore.

*In Zusammenarbeit mit der Technischen Hochschule der Universität von Mailand geplant, sind manuelle Schnitte von Feinsteinzeug großer Abmessungen bis zu einer Stärke von einem Zentimeter möglich.*

Conçue en collaboration avec le Politecnico de l'Université de Milan, permet la découpe manuelle de plaques en grès porcelainé de grandes dimensions jusqu'à un centimètre d'épaisseur.

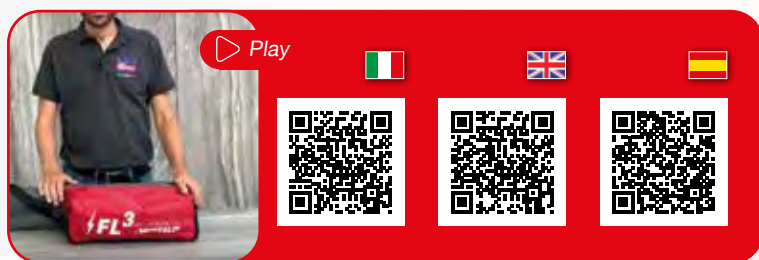

Senza ventose  
 Ohne Saugenapf  
 Sans ventouse



Facile e immediato sistema di selezione delle rotelle in Titanio.  
*Titanrad Auswahlssystem. Einfach und schnell verstellbar.*  
*Système de sélection des roulettes en Titane. Simple et immédiat.*

Art.						
FL3	cm 340	inch 134	max cm 1	max inch 3/8	kg 8,0	BOX C/1

1 Sistema di selezione delle rotelle in Titanio  
*Titanräder nach Wahl verwendbar*  
*Système de sélection des roulettes en Titane*

2 Aggancio elastico rapido  
*Schnelles elastisches Einspannen*  
*Attache élastique rapide*

3 Separatore con doppio sistema di spacco  
*Separator mit Doppel-Split-System*  
*Séparateur avec double système de fente*

Ø 20mm (3/4")

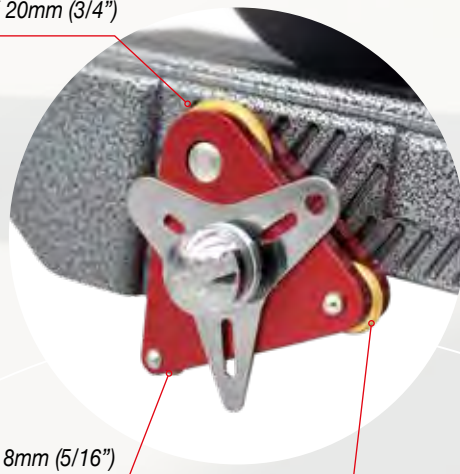

Ø 8mm (5/16")

Ø 12mm (1/2")

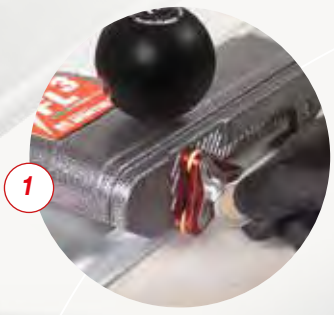

1



2



2 x 120 cm

1 x 40 + 80 cm



3

pg. 47

pg. 107 → Espositore  
*Austellmodul*  
*Affichage*

pg. 52 → Ricambi  
*Ersatzteile*  
*Pieces detachees*

# MOTO FLASH LINE 2



Un sistema senza limiti per il taglio a secco

*Trockenes no limits-Schneidsystem*

*Un système pour la découpe à sec no limits.*

Evoluzione motorizzata del sistema di taglio manuale Flash line per piastrelle e lastre fino a 4 cm di spessore. La macchina ha in sé tutti i vantaggi di FLASH LINE (facilità di trasporto, leggerezza, precisione, sistema antiscivolo brevettato senza utilizzo di ventose) con l'aggiunta di una testa motorizzata munita di disco diamantato professionale per ceramica e gres porcellanato.

*Motorisierte Evolution des manuellen Schnittsystems Flash Line für Fliesen und Platten bis zu einer Stärke von 4 cm. Die Maschine hat alle Vorteile von FLASH LINE einfacher leichter Transport, Leichtigkeit, Präzision, patentiertes Antirutschsystem ohne den Einsatz von Saugnapfen. Hinzu kommt ein robustes Agregat, das mit einer professionellen Diamantscheibe für Keramik und Feinsteinzeug ausgestattet ist.*

*Évolution motorisée du système de découpe manuelle Flash line pour les carrelages et les plaques jusqu'à 4 cm d'épaisseur. La machine possède tous les avantages de FLASH LINE (facilité de transport, légèreté, précision, système antiglisse breveté sans utiliser de ventouses) avec l'ajout d'une agrégat motorisé équipé de scie diamantée professionnelle pour la céramique et le grès porcelainé.*



Art.									
		cm	inch	max cm	max inch	mm	inch		
MFL2-SH	230V~ 1,6kW (2,1HP) 50/60 Hz · 5500 rpm	330	130	2	3/4	150/30	6 / 1-3/16	12,3	C/1
MFL2-SH-115V	110/120V~ 1,6kW (2,1HP) 50/60 Hz · 5000 rpm	330	130	2	3/4	150/30	6 / 1-3/16	12,8	C/1
MFL2-SH-PU (Power Unit)	230V~ 1,6kW (2,1HP) 50/60 Hz · 5500 rpm	330	130	2	3/4	150/30	6 / 1-3/16	6,5	C/1
MFL2-SH-PU-115V (Power Unit)	110/120V~ 1,6kW (2,1HP) 50/60 Hz · 5000 rpm	330	130	2	3/4	150/30	6 / 1-3/16	6,9	C/1

- Collegare ad un aspiratore professionale  
An einen professionellen Staubsauger anschließen  
Connecter à un aspirateur professionnel

1

Art. TCS150MFL

Disco di serie

2

Standard-Scheibe

Disque standard



Art. MFL2-SH



Art. MFL2-SH-PU





Massima ergonomia  
 Höchste Ergonomie  
 Ergonomie maximale



Art. LPH190MFL

Aspirazione "NO DUST" con regolazione automatica, garantisce l'assenza di polvere ed un raffreddamento ottimale  
 "NO DUST"-Absaugung mit automatischer Regulierung, garantiert staubfrei und eine optimale Kühlung.  
 Aspiration « NO DUST » avec réglage automatique qui garantit l'absence de poussière et un refroidissement optimal.

## OPTIONAL

Art. CSS150

Disco diamantato supersottile per lastre sottili in grès porcellanato.  
*Superdünne Diamanttrennscheibe für Feinsteinzeugplatten.*  
*Disque diamant super mince pour dalles de grès cérame mince.*

	Ø 150/30mm Ø 6/1-3/16 inch		3 ÷ 8mm 1/8 ÷ 5/16 inch
---	-------------------------------	---	----------------------------

Massima finitura - Velocità ridotta - Non forzare  
 Maximales finish - Reduzierte Geschwindigkeit - Ohne Druck  
 Finition maximale - Vitesse réduite - Ne forcez pas



pg.  
70

## OPTIONAL

Art. TBH150

Disco diamantato per grès porcellanato alto spessore e granito.  
*Diamanttrennscheibe für dickes Feinsteinzeug und Granit.*  
*Disque diamant pour grès cérame à haute épaisseur et granit.*

	Ø 150/30mm Ø 6/1-3/16 inch		12 ÷ 20mm 1/2 ÷ 3/4 inch
---	-------------------------------	---	-----------------------------

Speciale per Grès porcellanato da 2 cm max  
 Speziell für Feinsteinzeug bis 2 cm  
 Spécial pour grès cérame de 2 cm max.



pg.  
80

## OPTIONAL

Art. LPH190MFL

Disco diamantato per grès porcellanato alto spessore e granito.  
*Diamanttrennscheibe für dickes Feinsteinzeug und Granit.*  
*Disque diamant pour grès cérame à haute épaisseur et granit.*

	Ø 190/30mm Ø 7,5/1-3/16 inch		20 ÷ 40mm 3/4 ÷ 1-1/2 inch
---	---------------------------------	---	-------------------------------

Speciale per Grès porcellanato da 4 cm max  
 Speziell für Feinsteinzeug bis 4 cm  
 Spécial pour grès cérame de 4 cm max.



## OPTIONAL

Art. MT-H00V

Aspiratore professionale per polveri e liquidi.  
*Profi-Sauger für Staub und Flüssigkeit.*  
*Aspirateur professionnel pour poudre et liquide.*

	 CAPACITA' BIDONE TANKKAPAZITÄT CAPACITÉ DU RÉSERVOIR	 FLUSSO ARIA MAX MAX LUFTSTROM DÉBIT D'AIR MAX	
	L	m <sup>3</sup> /h	kg
230V~/1,2kW	50	166 (45 lt/sec)	11

Ricambi | Ersatzteile | Pieces detachees

Art. MT-H00V01



Elemento filtrante  
 Filterelement  
 Élément filtrant

Art. MT-H00V02



Sacchetto raccogli-polvere  
 Filterbeutel  
 Sac collecteur de poussière



# BATTLE PRO

IT Ventosa battente per piastrelle e lastre.  
 DE Elektrischer Vibrationsaugrüttler für Fliesen und Platten.  
 FR Ventouse à levier avec percussions pour carreaux et dalles.

CE

SPECIAL RED RUBBER  
NO STAMP

3 SPEED  
FOR ALL  
THICKNESS



3 Velocità  
3 Speed  
3 Velocidades

2 batterie 16V 2 Ah  
2 Batterien 16V 2 Ah  
2 batteries 16V 2Ah



Art. BTL-P-13

Estensore di vibrazione **INCLUSO**, area interessata più ampia  
 Vibration Extender **INKLUSIVE**, größerer Wirkungsbereich  
 Extension de vibration **INCLUDE**, zone affectée plus large

pg. 52 → Ricambi  
 Ersatzteile  
 Pieces detachees



Art.				MIN./MAX rpm	 mm (inch)		
	2	16V -Li-ion 2 Ah - 32Wh	h	5.000 ÷ 12.000	130 (5-1/8)	1,35	S/1
BATTLE-PRO-2B	2	16V -Li-ion 2 Ah - 32Wh	2,5	5.000 ÷ 12.000	130 (5-1/8)	1,35	S/1

# BATTILONE

IT Ventosa battente per piastrelle e lastre.  
 DE Elektrischer Vibrationssaugrüttler für Fliesen und Platten.  
 FR Ventouse à levier avec percussions pour carreaux et dalles.



2 batterie 20V 1,5 Ah  
 2 Batterien 20V 1,5 Ah  
 2 batteries 20V 1,5 Ah



Art. BTL-P-13

Estensore di vibrazione **INCLUSO**, area interessata più ampia  
 Vibration Extender **INKLUSIVE**, größerer Wirkungsbereich  
 Extension de vibration **INCLUDE**, zone affectée plus large

pg. 52

Ricambi  
 Ersatzteile  
 Pièces détachées



Art.				MIN./MAX rpm	 mm (inch)		
BATTILONE	2	20V -Li-ion 1,5 Ah - 30Wh	2	4.000 ÷ 7.000	160 (6-5/16)	2,2	S/1

# TOPPROFILE



CE



L'innovativo sistema di PROFILATURA  
 Das innovative PROFILIERUNGSSYSTEM  
 Le système de PROFILAGE innovant

Sistema di profilatura a secco per piastrelle e lastre, consente di realizzare jolly, biselli, profili raggiati su lastre in gres porcellanato, ceramica e qualsiasi materiale lapideo di ogni dimensione.

Trocken-Profil Frässystem zur Anwendung an Fliesen und Platten. Es ermöglicht die Herstellung von Fasen, Gehrungen, runden und geraden Kanten an Platten aus Feinsteinzeug, Keramik und sonstigen Natursteinmaterialien jeder Größe.

Système de profilage à sec pour carreaux et dalles, permet de réaliser des jolly, biseaux, profils chanfreinés sur dalles en grès porcelaine, céramique et n'importe quel matériel pierreux de toutes dimensions.

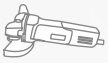

Art.			
		kg	
TOPPROFILE	230 V~ · 800 W · 50/60 Hz · 11.000 RPM	4,7	C/1
TOPPROFILE-115V	110/120 V~ · 900 W · 50/60 Hz · 11.000 RPM	4,7	C/1



1 Protezione in policarbonato  
 1 Schutzvorrichtung aus Polycarbonat  
 1 Protection en polycarbonate

2 Telaio in alluminio  
 2 Aluminiumrahmen  
 2 Châssis en aluminium

3 Base in nylon intercambiabile  
 3 Basis aus auswechselbarem Nylon  
 3 Base en nylon interchangeable

4 Pratica e robusta borsa in cordura per il trasporto  
 4 Praktische und robuste Tasche aus Cordura für den Transport  
 4 Sac de transport en cordura, pratique et robuste

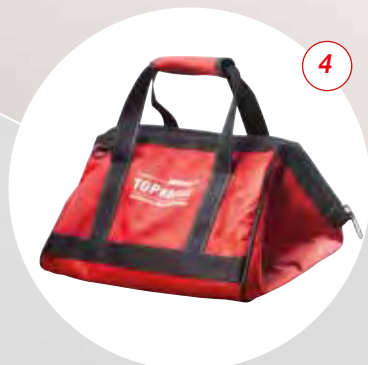
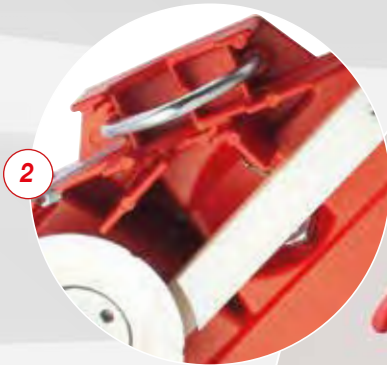
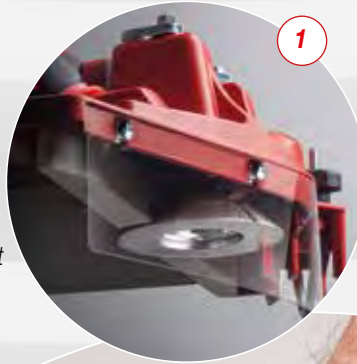

pg.  
33

Aspiratore professionale per polveri e liquidi  
 Profi-Sauger für Staub und Flüssigkeit  
 Aspirateur professionnel pour poudre et liquide

**INCLUSO  
INKLUSIVE  
INCLUDE**

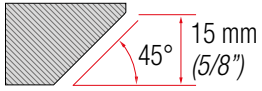

## TOPPROFILE



Art. FPE15TP

Grana media | Körnung mittel | Grain moyen

## SUPERPROFILE



Art. FPE15SP

Grana media | Körnung mittel | Grain moyen

## OPTIONAL

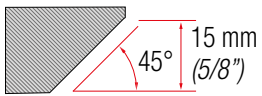

Art. FPE15TPGF

Grana fine | Körnung fein | Grain fin

Art. FPE15SPGF

Grana fine | Körnung fein | Grain fin

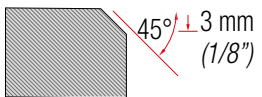

Art. FPE03TP



Art. FPE03SP

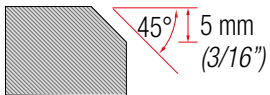

Art. FPE05TP



Art. FPE05SP

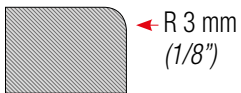

Art. FPB03TP



Art. FPB03SP

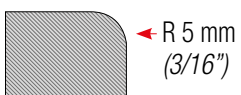

Art. FPB05TP



Art. FPB05SP

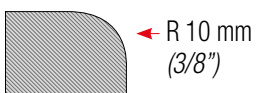

Art. FPB10TP



Art. FPB10SP

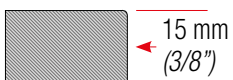

Art. FPZS15TP



Art. FPZS15SP



Attrezzature elettriche e manuali  
*Elektrische und manuelle Ausrüstung*  
*Équipements électriques et manuels*



# F1 BROOKLYN



IT Taglierina elettrica ad acqua.

DE Elektrische Schneidmaschine mit Wasserkühlung.

FR Découpeuse électrique à eau.

Piani in acciaio inox  
Arbeitsflächen aus Edelstahl  
Plans de travail en acier inoxydable

Motore potente 3hp, disco Ø 250mm  
Kraftvoller 3PS-Motor, 250mm Scheiben-Durchmesser  
Puissance moteur: 3HP, disque diamant Ø 250 mm

Art. SCX250  
DNA - Disco diamantato incluso  
DNA - Diamantscheibe inklusive  
DNA - Disque diamanté inclus

GOLD LINE  
"HIGH TECHNOLOGY"

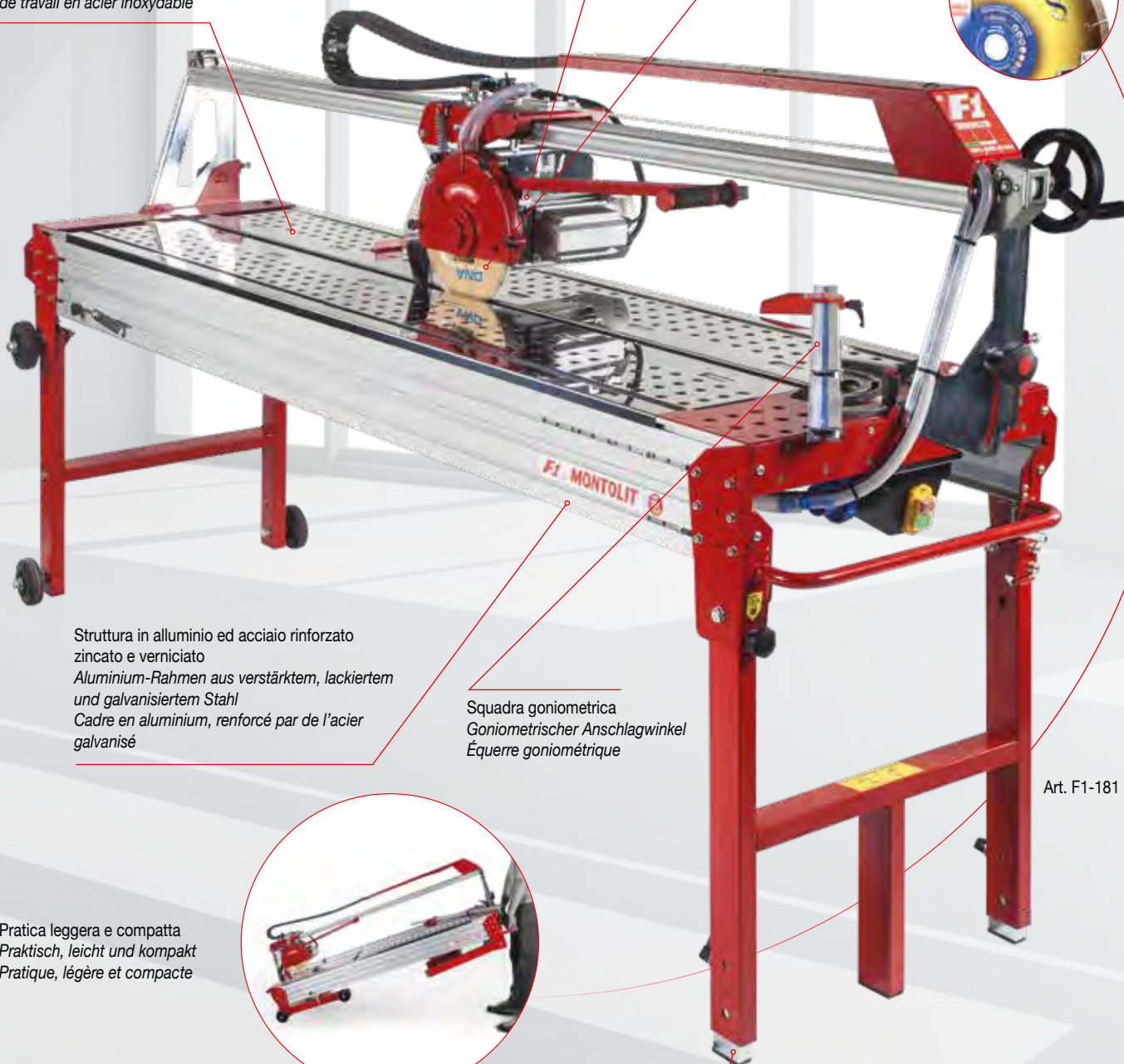

Struttura in alluminio ed acciaio rinforzato  
zincato e verniciato  
Aluminium-Rahmen aus verstärktem, lackiertem  
und galvanisiertem Stahl  
Cadre en aluminium, renforcé par de l'acier  
galvanisé

Squadra goniometrica  
Goniometrischer Anschlagwinkel  
Équerre goniométrique

Art. F1-181

Pratica leggera e compatta  
Praktisch, leicht und kompakt  
Pratique, légère et compacte



Sistema brevettato per una planarità ottimale (131/151/181cm)  
Patentiertes Torsions-Ausgleichsystem (131/151/181cm)  
Système breveté pour une planéité optimale (131/151/181cm)

Play

pg. 53 → Ricambi  
Ersatzteile  
Pièces détachées

## F1-101

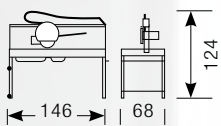

## F1-131

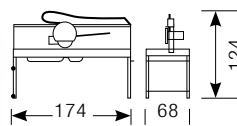



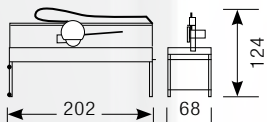

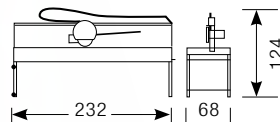

## F1-151



## F1-181



Art.											
		cm	inch	cm	inch	max cm	max inch	mm	inch		
F1-101	230V~/2,2kW (3HP) 50Hz/2.800rpm	101	40	71 x 71	28 x 28	5	2	250/25,4	10 / 1	75	C/1
F1-131	230V~/2,2kW (3HP) 50Hz/2.800rpm	131	51,5	92 x 92	36 x 36	5	2	250/25,4	10 / 1	85	C/1
F1-151	230V~/2,2kW (3HP) 50Hz/2.800rpm	151	59,5	106 x 106	41,5 x 41,5	5	2	250/25,4	10 / 1	100	C/1
F1-181	230V~/2,2kW (3HP) 50Hz/2.800rpm	181	71,5	128 x 128	50 x 50	5	2	250/25,4	10 / 1	112	C/1
F1-101-115V	115V~/1,5kW (2HP) 60Hz/3.360rpm	101	40	71 x 71	28 x 28	5	2	250/25,4	10 / 1	75	C/1
F1-131-115V	115V~/1,5kW (2HP) 60Hz/3.360rpm	131	51,5	92 x 92	36 x 36	5	2	250/25,4	10 / 1	85	C/1
F1-151-115V	115V~/1,5kW (2HP) 60Hz/3.360rpm	151	59,5	106 x 106	41,5 x 41,5	5	2	250/25,4	10 / 1	100	C/1
F1-181-115V	115V~/1,5kW (2HP) 60Hz/3.360rpm	181	71,5	128 x 128	50 x 50	5	2	250/25,4	10 / 1	112	C/1

## OPTIONALS



### Art. 58E

- IT** Tappetino in gomma per mosaico, piastrelle in vetro, delicate o sottili (3mm).
- DE** Gummimatte, besonders geeignet für Mosaik und empfindliche, sehr dünne 3mm Glasfliesen.
- FR** Tapis en caoutchouc pour carreaux en mosaïque, verre ou carrelage fin et délicat (3 mm).



### Art. 1051

- IT** Tavolino di supporto.
- DE** Stütztisch.
- FR** Table de support.



### Art. 1305F1

Standard su art. F1-181  
Standard bei art. F1-181  
Standard pour art. F1-181

- IT** Kit avanzamento con volantino - sistema che fornisce prestazioni di taglio senza sforzo e facile.
- DE** Hand-Kurbelführungsset - ein System für müheloses und einfaches Schneiden - vom Start bis zum Ziel.
- FR** Kit d'avancement manuel - système qui offre des performances de coupe facile et sans effort.



### Art. 1198F1

- IT** Contrasto di precisione per taglio o jolly ripetitivi.
- DE** Präzisions-Seitenwinkel für wiederholte Schnitte und Gehrungen.
- FR** Équerre latérale de précision pour les coupes répétitives ou jolly.

# F2

IT Taglierina elettrica ad acqua.  
 DE Elektrische Tisch-Schneidmaschine mit Wasserkühlung.  
 FR Découpeuse électrique à eau.



Piano di lavoro in acciaio inox  
 Arbeitsfläch aus Edelstahl  
 Plan de travail en acier inoxydable

Art. CE  
 Disco diamantato incluso  
 Inklusive Diamantscheibe  
 Disque diamanté inclus

ABS antiurto  
 Stoßfestes ABS  
 ABS résistant aux chocs



pg. 53 → Ricambi  
 Ersatzteile  
 Pièces détachées

Art.										
			cm	inch	max cm	max inch	mm	inch		
905EV02	230V~ / 0,45kW (0,6HP) 50Hz / 2.800rpm	Illimitato Unbegrenzt Illimité	15 x 15	6 x 6	3,5	1-3/8	180/25,4	7 / 1	7,1	S/1
906EV02	115V~ / 0,4kW (0,55HP) 50-60Hz / 2.800-3360rpm	Illimitato Unbegrenzt Illimité	15 x 15	6 x 6	3,5	1-3/8	180/25,4	7 / 1	7,1	S/1

# BIMBO FORATUTTO



IT Elettroforatrice ad acqua per frese diamantate.  
 DE Elektrobohrmaschine für Wassergekühlte Diamantfräser.  
 FR Perceuse électrique à fraises diamantées (utilisation à eau).



pg. 93 → Frese diamantate non incluse  
 Ohne Diamant-Bohrkronen  
 Fraises diamantées pas incluse

pg. 53 → Ricambi  
 Ersatzteile  
 Pieces detachees

Art.								
			max mm	max inch	max cm	max inch		
915	230V~ / 0,4kW (0,55HP) 1.400 rpm	M16 Optional: W5/8"	120	4-3/4	3,5	1-3/4	17	C/1
916	115V~ / 0,4kW (0,55HP) 1.400 rpm	M16 Optional: W5/8"	120	4-3/4	3,5	1-3/4	17	C/1

## ACCESSORI PER LA FORATURA AD ACQUA

AUSRÜSTUNG FÜR "NABBOHRUNG" - OUTILLAGE POUR LE PERÇAGE A EAU

Art. PS92	Raccordo portapunta per MU (x artt. 915/916/CVG12) Bohrhalter mit Madenschraube für MU (x artt. 915/916/CVG12) Raccord porte-foret pour MU (x artt. 915/916/CVG12)	
Art. AUFA	Raccordo per trapano - M16 (x artt. FA/FAV) Adapter für Bohrmaschine - M16 (x artt. FA/FAV) Adaptateur pour perceuse - M16 (x artt. FA/FAV)	
Art. 88	Mandrino a punta centrale retraente - M16 (x artt. FA/FAV) Spindel mit gefedertem Zentrierbohrer - M16 (x artt. FA/FAV) Mandrin a pointe central escamotable - M16 (x artt. FA/FAV)	
Art. CVG12	Convogliatore d'acqua completo di tanica Wasserleitelement komplett mit Kanister Asperseur d'eau avec réservoir	
Art. VTKIT	Ventose per foratura con acqua (Ø 40mm + Ø 60mm) Saugnäpfe für die Bohrung mit Wasser (Ø 40mm + Ø 60mm) Ventouses pour perçage avec eau (Ø 40mm + Ø 60mm)	
Art. 89	Riduzione M16 - G 1/2" Adapter M16 - G 1/2" Adaptateur M16 - G 1/2"	

IT Accessori per foretti diamantati a settori.  
 DE Zubehör für segmentierte Diamantbohrkronen.  
 FR Accessoires pour forets diamants a segments.

Art.	mm	inch	e		
AM16F	G 1/2"  M16				
AM16M	G 1/2"  M16				
AM16F18	M18  M16				
MT-AU80	 M16 Ø 12mm NICHEL-CROMO-MOLIBDENO	80	3-1/4		
MT-AU230		230	9		
MT-AS80	 M16 SDS PLUS NICHEL-CROMO-MOLIBDENO	80	3-1/4		
MT-AS230		230	9		
MT-ASMAX	 M16 SDS MAX NICHEL-CROMO-MOLIBDENO	170	6-11/16		
M-PC240	 M16 attacco conico   konischer Angriff   attaque conique Ø 10mm x artt. M-AU80 · M-AU180 · M-AU280 · M-AS100 · M-AS180 · M-AS280 · M-ASMAX	240	9,5		
MT-PC220	 M16 x artt. MT-AU80 · MT-AU230 · MT-AS80 · MT-AS230 · MT-ASMAX · MT-PR200	220	8-5/8		
MT-PR200	 M16 M16 NICHEL-CROMO-MOLIBDENO x mod. FUTS - FUXT	250	10		
M-PR-W100	 M16 con passaggio aspirazione/liquidi 1" 1/4 mit Saug-/Flüssigkeitsdurchgang   avec passage d'aspiration/liquide	100	4		
M-PR-W200		200	8		
M-PR-W500		500	20		

# CORE EM

IT Carotatrici professionali con accessori.  
 DE Professionelles Kernbohrmaschine mit Zubehör.  
 FR Machines professionnelles de carottage avec accessoires.



Art. EM18W

Art.				UTILIZZI / USE / USAR		
		max mm	M16 1/2"gas -1-1/4"		kg	BOX
EM18W	230V~/1,8kW (2,46HP) 1000/2600 rpm	180	M16 1/2"gas -1-1/4"	+  +	7,3	C/1
EM25W*	230V~/2,5kW (3,35HP) 310/450/960 rpm	250	1/2"gas -1-1/4"		11,5	C/1
EM33W*	230V~/3,3kW (4,49HP) 230/510/730 rpm	350	1/2"gas -1-1/4"		12,5	C/1

\* A richiesta - Auf Anfrage - Sur demande

IT Supporto per carotatrici.  
 DE Unterstützung für Kernbohrmaschinen.  
 FR Support pour machines de carottage.



Art.							
		suggested mm	max mm	mm		kg	BOX
EMB13	0° ÷ 45°	200	250	580	Attacco con collare Ø 60 mm incluso Inklusive Ø 60 mm Arretierung Collier de fixation Ø 60 mm inclus	13	C/1
EMB16*	0° ÷ 45°	300	400	610	Attacco rapido - Collare Ø 60mm optional Schnellkupplung - Manschette Ø 60mm optional Raccord rapide - Collier Ø 60mm en option	18	C/1
EMB32*	0° ÷ 45°	350	600	650	Attacco rapido - Collare Ø 60mm optional Schnellkupplung - Manschette Ø 60mm optional Raccord rapide - Collier Ø 60mm en option	19	C/1

\* A richiesta - Auf Anfrage - Sur demande

# CRAB



**IT** Tenaglia professionale per piastrellista speciale per gres porcellanato.  
**DE** Professionelle Zange für hartes Feinsteinzeug, speziell entwickelt für Fliesenleger.  
**FR** Tenaille professionnelle pour carrelleur spéciale grès cérame.

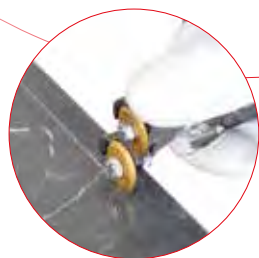

Art.		
33W	g 430	S/6

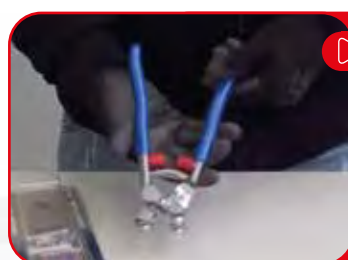

Play



Art. 242TW

## 54

Art. 54

**IT** Tenaglia per piastrellista a branche incisive regolabili.  
**DE** Zange für Fliesenleger mit einstellbaren Schnittbacken.  
**FR** Tenaille pour carrelleur a machoires tranchantes réglables.

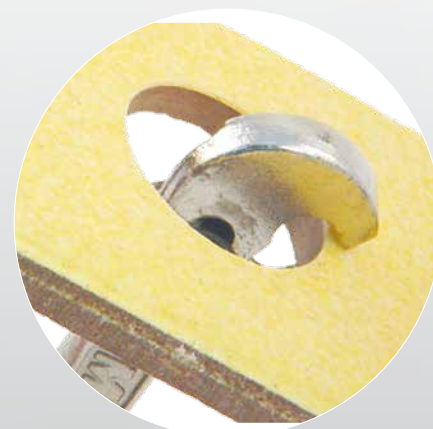

# MOSAIC



- IT** Tenaglia professionale per mosaico ceramico e vetroso.
- DE** Professionelle Zange für Glas, Keramik und Mosaik.
- FR** Tenaille professionnelle pour la mosaïque de céramique et de verre.



Art. 242TW

Art.		
55W2	380 g	S/6

[▶ Play](#)

## 56RJ

Art. 56RJ

- IT** Doppio sistema di spacco Max 15mm.
- DE** Parallel-BrechSystem - Max 15mm.
- FR** Double système de coupe - Max 15mm.



## 56R

Art. 56R

- IT** Doppio sistema di spacco Max 20mm.
- DE** Parallel-BrechSystem - Max 20mm.
- FR** Double système de coupe - Max 20mm.



# GRES LINEA

NEW 2026

- IT Matita speciale per piastrellisti.
- DE Spezialstift für Fliesenleger.
- FR Crayon spécial pour carreleurs.



## SPECIAL MINERAL ROCK

Scrivi su ogni superficie ceramica, si cancella facilmente.

Schreibt auf jeder Keramikoberfläche und lässt sich leicht wieder abwischen.

Écrit sur toutes les surfaces céramiques et s'efface facilement.

# GECO

- IT Ventosa per piastrellista.
- DE Saugnapf für Fliesenleger.
- FR Ventouse pour carreleur.



Art.	mm	kg	
GECO	220	1,100	C/1

SPECIAL RED RUBBER  
NO STAMP

# VT80

- IT Ventosa per piastrellista.
- DE Saugnapf für Fliesenleger.
- FR Ventouse pour carreleur.



Art.	mm	
VT-80	80	B/1



# MONTHOR



SPECIAL RED RUBBER  
NO STAMP



- IT** Mazzette in gomma ideali per ogni tipo di ceramica delicata/sottile e gres porcellanato.  
**DE** Gummihammer ideal für alle Arten von empfindlicher/dünner Keramik und Feinsteinzeug.  
**FR** Maillets en caoutchouc idéaux pour tous les types de carreaux céramique et grès cérame délicats/fins.



Art.		
MONTHOR500	500	S/4
MONTHOR1000	1.000	S/4

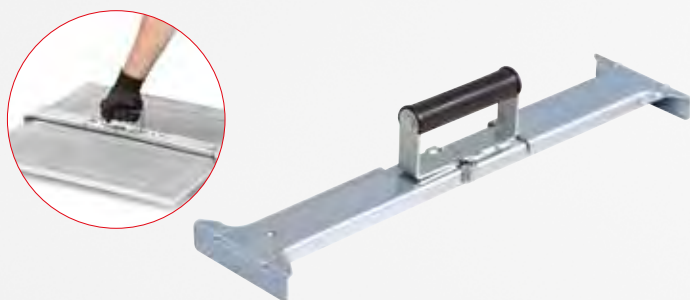

## 16-S

- IT** Sollevalastre per alto spessore e superfice strutturata.  
**DE** Plattenheber für zum Setzen von Feinsteinzeug - Gartenplatten.  
**FR** Elévateur et positionneur pour carreaux céram forte épaisseur.



Art.			
16-S	50 ÷ 65	20 ÷ 25 -3/4	C/2

## 25V

- IT** Cutter per vetro/piastrelle/lastre sottili.  
**DE** Messer für Glas/Keramik/grosse Formate.  
**FR** Cutter pour verre/ceramique/carreaux grands formats.



Art.	
25V	B/1

# MONTHOR 2000

- IT Mazza per blocchi / autobloccanti.
- DE Vorschlaghammer für Blöcke/Verbund-und Gehwegplatten.
- FR Masse pour blocs/autobloquants.

Art. MT-24

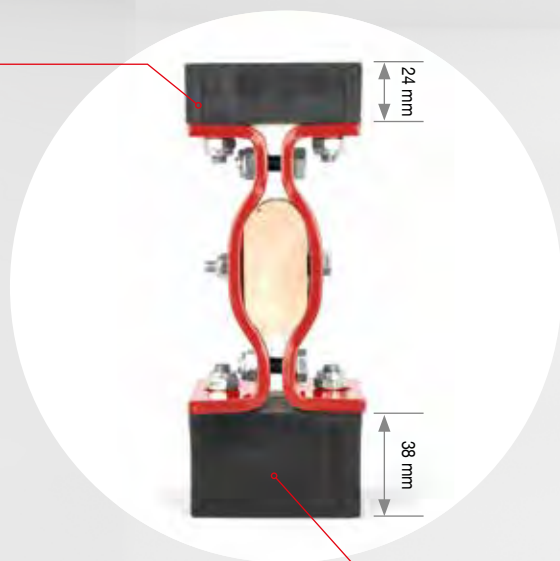

Art. MT-38

Art.		
MONTHOR2000	2.000	V/1

# PINZONE

- IT Pinza di sollevamento per cordoli.
- DE Bordsteinzange zum Setzen von Bordsteinen.
- FR Pince manuelle pour la pose de bordures.

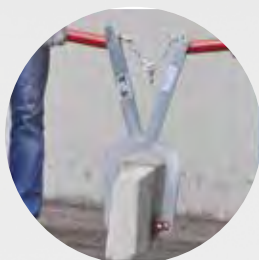
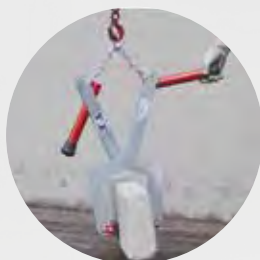

Art.		Portata Max Max load		
	cm	kg	kg	
16	5 ÷ 18	200	11	C/1
	inch.			
	2 ÷ 7 1/2			

# TAGLIATEGOLE

- IT Tagliategole per tegole in cemento e cotto.
- DE Dachziegel Handschneider.
- FR Découpeuse a tuiles.



Art.		
42	7	C/1

# BLOCKUT



IT Tranciablocchi.  
 DE Gehweg Plattenspalter.  
 FR Découpeuse à dalles et à pavé.



pg. 52 → Ricambi  
 Ersatzteile  
 Pieces detachees

Art.							
	cm	inch.	cm	inch.	kg	kg	BOX
BLOCKUT	33	13	2 ÷ 11	3/4 ÷ 4-3/8	4.100	28	C/1

# X-WORKS



IT Banco di lavoro per piastrellista.  
 DE Arbeitstisch für Fliesenleger.  
 FR Table de travail pour carreleur.

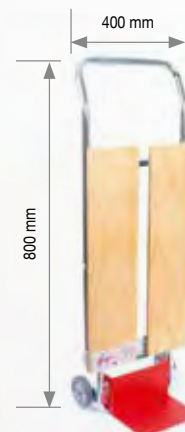
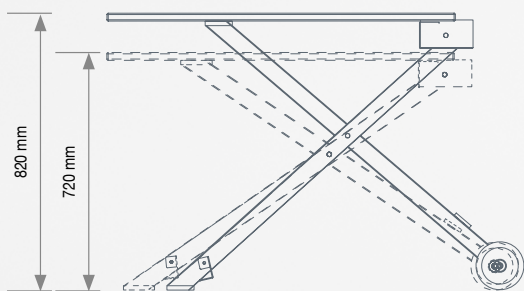

Art.		
	kg	BOX
X-WORKS	18	C/1

				
	Art.		FLASH LINE - FL3	BLOCKUT
 Ø 8 mm	240T	B/1	✓	
 Ø 12 mm	241T	S/12	✓	
 Ø 20 mm	242T-FL3	B/1	✓	
	FL3-04	B/1	✓	
	FL3-03	S/1	✓	
	56RJ	S/1	✓	
	300-FL-02	S/1	✓	
	FL3-02	S/1	✓	
	FL3-01	S/1	✓	
	208BC	V/1		✓
	209BC	V/1		✓
	302	V/1		✓

							
	Art.		BATTILE	BATTILE PRO	BATTILONE	GECONE	GECONE JR
	BTL-03	V/1	✓				
	BTL-P-06	V/1		✓			
	BATTILONE-02	V/1			✓		
	BTL-01	S/1	✓				
	BTL-P-08	S/1		✓			
	BATTILONE-07	S/1			✓		
	GECONE-08	V/1				✓	
	BTL-P-04	V/1		✓			
	BATTILONE-01	V/1			✓		
	GECONE-01	V/1				✓	
	GECONE-02	V/1				✓	
	GECONE JR-02	V/1					✓
	GECONE-03	V/1				✓	
	GECONE JR-03	V/1					✓
	GECONE-04	V/1				✓	
	BTL-02	B/1	✓				
	BTL-09	V/1	✓				
	BTL-P-11	V/1		✓			
	BATTILONE-08	V/1			✓		
	GECONE-09	V/1				✓	

															
				F1 BROOKLYN				F2				BIMBO FORATUTTO			
	Art.			F1-101	F1-131	F1-151	F1-181	F1-101-115V	F1-131-115V	F1-151-115V	F1-181-115V	905EV02	906EV02 (115V~)	915	916 (115V~)
	1080MB	V/1		✓	✓	✓	✓								
	1081MB	V/1						✓	✓	✓	✓				
	1092EV02	V/1										✓			
	1093EV02	V/1											✓		
	1075	V/1												✓	
	1076	V/1													✓
	1082	V/1		✓	✓										
	1082F1	V/1				✓	✓								
	1083	V/1						✓	✓						
	1083F1	V/1								✓	✓				
	1191	V/1		✓	✓	✓	✓								
	1155	V/1						✓	✓	✓	✓				
	1096EV02	V/1										✓			
	1097EV02	V/1											✓		
	1053	V/1												✓	
	1054	V/1													✓
	1077	V/1												✓	
	1206F1	V/1		✓	✓	✓	✓	✓	✓	✓	✓				
	1208F1	V/1		✓	✓	✓	✓	✓	✓	✓	✓				
	1110EV02	V/1										✓	✓		
	1195	V/1		✓	✓	✓	✓	✓	✓	✓	✓				
	1095F1SX	V/1		✓	✓	✓	✓	✓	✓	✓	✓				
	1095F1DX	V/1		✓	✓	✓	✓	✓	✓	✓	✓				
	1089EV	V/1		✓	✓			✓	✓						
	1198EV	V/1				✓	✓				✓	✓			
	1113EV02	V/1										✓	✓		
	1114EV02	V/1										✓	✓		
	1073EV	V/1		✓	✓	✓	✓	✓	✓	✓	✓				
	1201	S/1		✓	✓	✓	✓	✓	✓	✓	✓				
	302F1	V/1		✓	✓	✓	✓	✓	✓	✓	✓				
	1072	V/1												✓	✓

# LAMA UNIVERSALE PER LEGNO



IT Lame circolari universali per legno.  
 DE Universal-Stichsägeblätter für Holz.  
 FR Lames circulaires universel pour bois.

Art.	Ø		mm	N°	mm	BOX
	mm	inch				
813	315	12,5	30/25,4	48	3,2	S/1
814	350	14	35/25,4	54	3,4	S/1

# WOOD CARVER



IT Lame circolari per legno.  
 DE Kreissägeblätter für Holz.  
 FR Lames circulaires pour le bois.

Art.	Ø		mm	N°	BOX
	mm	inch			
115LL	115	4,5	22,2	6	B/1
230LL	230	9	22,2	48	B/1

**ATTENZIONE!**

Verificare che l'utensile sia compatibile con la macchina sulla quale verrà montato consultandone il manuale d'uso e di sicurezza.

**ACHTUNG!**

Achten Sie darauf, dass die Werkzeuge mit der Maschinen kompatibel sind. Achten Sie auf die Gebrauchs- und Sicherheitsanleitung.

**ATTENTION!**

Contrôler que ce disque soit compatible avec les machines sur lesquelles il sera assemblé en consultant leurs manuels d'instructions et des règles de sécurité.

# TUTORCUT-U



IT Guida assistita per tagli perfetti.  
 DE Unterstützte Führung für perfekte Schnitte.  
 FR Guidage assisté pour des coupes parfaites.



Poliamide antitraccia resistente all'usura.  
 Verschleißfestes fleckenfreies-Polyamid.  
 Polyamide anti-trace résistant à l'usure.

Adatto alle più comuni smerigliatrici.  
 Für die gebräuchlichsten Winkelschleifer geeignet.  
 Convient aux ponceuses habituelles.



Rotazioni disco/TutorCut differenziate e indipendenti.  
 Unterschiedliche und unabhängige Rotation von Scheibe und TutorCut.  
 Rotations disque/TutorCut différenciées et indépendantes.

Cuscinetto a sfere ermetico  
 Hermetisches Kugellager.  
 Roulement à billes hermétique.

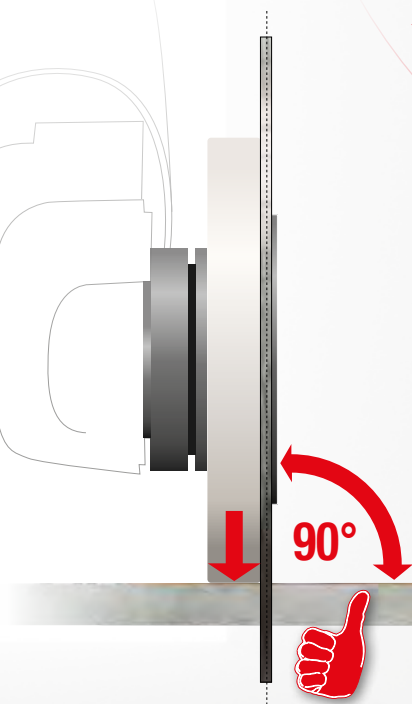

Art.



TUTORCUT115-U	x Ø 115mm	Ø 14mm	20mm	B/1
TUTORCUT125-U	x Ø 125mm	Ø 14mm	20mm	B/1
TUTORCUT115-U-16	x Ø 4,5"	Ø 5/8"	3/4"	B/1
TUTORCUT125-U-16	x Ø 5"	Ø 5/8"	3/4"	B/1



# DNA 4<sup>TH</sup>

DIAMONDS NETWORK ARRANGEMENT

**+100% PERFORMANCE\***

**+30% SPEED\***

**+20/50% LIFE\***

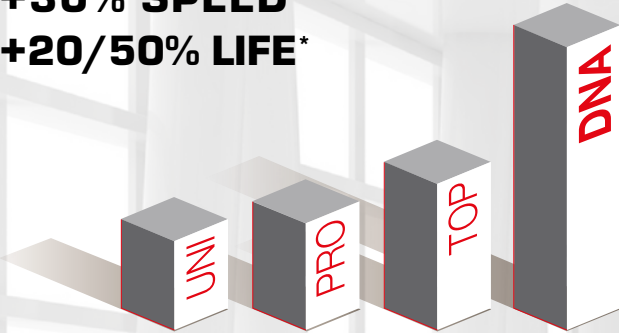

\*Test eseguiti su dischi diamantati Brevetti Montolit  
\*Tests mit Brevetti Montolit-Diamantscheiben durchgeführt  
\*Tests effectués sur des disques diamantés Montolit brevétés

DNA è una innovativa tecnologia che consiste nella particolare “distribuzione a rete variabile e tridimensionale controllata” dei granuli di diamante contenuti all’interno della parte tagliente degli utensili. Si posizionano le singole grane di diamante a piacimento a secondo del progetto. Con DNA i settori diamantati e comunque tutte le parti taglienti sinterizzate dell’utensile, contenendo la stessa e predefinita quantità di granuli distribuiti con micrometrica precisione, presentano le medesime caratteristiche ottimali espressamente progettate per l’ottenimento delle migliori performances.

*DNA ist eine innovative Technologie, die in der besonderen “Variable und gesteuerten Verteilung in dreidimensionalem Netz „der im Inneren des Schneidteils der Werkzeuge enthaltenen Diamantkörner besteht. Die einzelnen Diamantkörper nach Belieben und nach Projekt “anordnen „ können.*

*Mit DNA weisen die diamantbeschichteten Bereiche und jedenfalls alle gesinterten Schneidteile des Werkzeugs, die die gleiche und vorbestimmte Menge von mit mikrometrischer Genauigkeit verteilten Körner enthalten, die gleichen optimalen Eigenschaften auf, die ausdrücklich für die Erlangung der besten Leistungen geplant wurden.*

*DNA est une technologie innovante qui consiste en une «distribution particulière variable en réseau tridimensionnelle contrôlée» des granulés de diamant contenus à l’intérieur de la partie coupante des outils. Et possible «disposer» chaque grain de diamant au plaisir et selon le projet.*

*Avec DNA, les secteurs diamantés et dans tous les cas, toutes les parties coupantes frittées de l’outil, contenant la même quantité prédéfinie de granulés distribués avec une précision micrométrique, présentent les mêmes caractéristiques optimales expressément conçues pour l’obtention des meilleures performances.*

Particolare distribuzione con reticolo variabile e tridimensionale controllato di granuli di diamante.  
*Besondere Verteilung mit variablem und kontrolliertem dreidimensionalem Gitterwerk aus Diamantgranulat.*  
*Distribution particulière avec un treillis tridimensionnel variable et contrôlé de granules de diamant.*



Dischi diamantati  
*Diamanttrennscheiben*  
*Disques diamantes*



# SCX - SEGMENTS



**DNA 4<sup>TH</sup>**

Gres porcellanato/Ceramica "PRO"/Granito  
 Feinsteinzeug/Keramik "PRO"/Granit  
 Grès vitrifié/Céramique "PRO"/Granit

GOLD LINE  
 "HIGH TECHNOLOGY"



Velocità - Geschwindigkeit - Vitesse	Durata - Dauer - Durée	Finitura - Endbearbeitung - Finition
★★★★	★★★★	★★★★☆

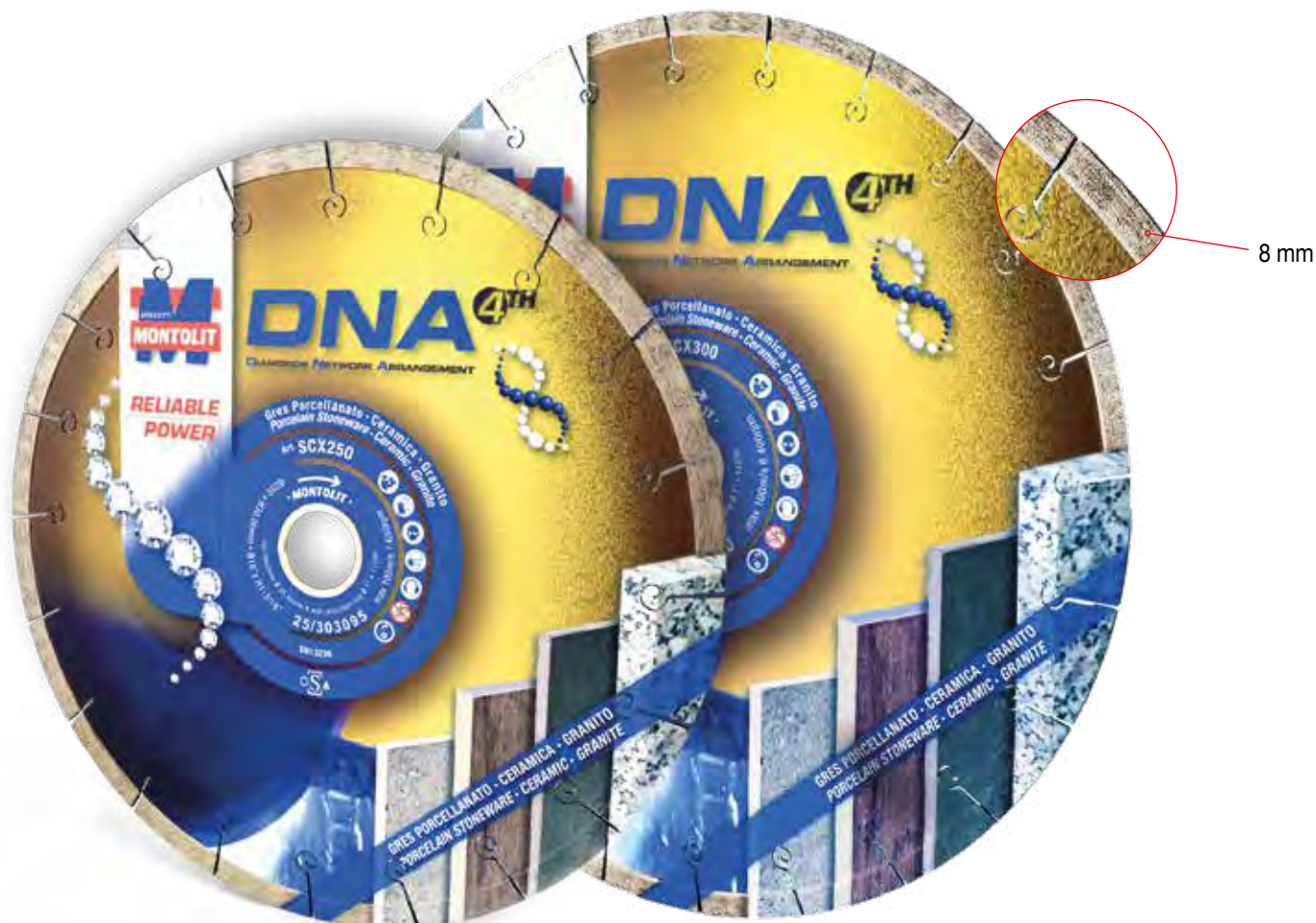

Art.



Art.	mm	inch	mm*	mm
SCX180	180	7	25,4/22,2	2,0
SCX200	200	8	30/25,4	2,0
SCX230	230	9	30/25,4	2,2
SCX250	250	10	30/25,4	2,2
SCX300	300	12	30/25,4	2,4
SCX350	350	14	30/25,4	2,4
SCX350/60	350	14	60/50	2,4
SCX400	400	16	60/50	3,2

\* 5/8 inch: Riduzione a richiesta • Reduzierung auf Anfrage • Réduction sur demande

IT	DE	FR	
Gres porcellanato	Feinsteinzeug	Grès vitrifié	★★★★★
Piastrelle in monocottura, klinker, cotto	Einbrandfliese (Keramikfliesen), klinker, cotto	Céramique monocuissons, klinker, brique	★★★★★
Piastrelle in granito e pietre dure	Granitfliesen und Harterstein	Carreaux de granit et de la pierre dure	★★★★★
Piastrelle in marmo	Marmorfliesen	Carreaux de marbre	★★★★☆
Piastrelle in bicottura	Doppelbrand Keramikfliesen	Céramique biccuisson	★★★☆☆

# SCX-S - SEGMENTS



**DNA 4<sup>TH</sup>**

Gres porcellanato/Gres porcellanato spessorato/  
Granito ceramico  
Feinsteinzeug /Dickes Feinsteinzeug/Keramischer Granit  
Grès vitrifié/Grès cérame à haute épaisseur/  
Granit céramique

GOLD LINE  
"HIGH TECHNOLOGY"

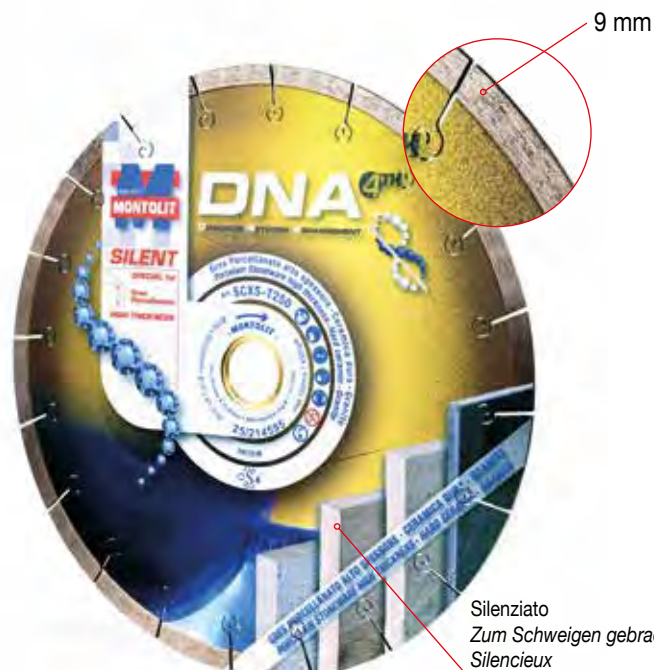

9 mm

Silenziato  
Zum Schweigen gebracht  
Silencieux



Speciale per gres porcellanato alto spessore  
Speziell für dickes Feinsteinzeug  
Spécial pour le grès cérame à haute épaisseur.

Velocità - Geschwindigkeit - Vitesse	Durata - Dauer - Durée	Finitura - Endbearbeitung - Finition
★★★★	★★★★	★★★★☆

Art.	Ø		Ø	
	mm	inch	mm *	mm
SCXS-T200	200	8	30/25,4	2,0
SCXS-T250	250	10	30/25,4	2,2
SCXS-T300	300	12	30/25,4	2,4
SCXS-T350	350	14	30/25,4	2,4
SCXS-T350/60	350	14	60/50	2,4
SCXS-T400	400	16	60/50	3,2

\* 5/8 inch: Riduzione a richiesta • Reduzierung auf Anfrage • Réduction sur demande

IT	DE	FR	
Gres porcellanato	Feinsteinzeug	Grès vitrifié	★★★★
Gres porcellanato molto duro	Harter-Feinsteinzeug	Grès vitrifié tres dure	★★★★
Gres porcellanato, monocottura, klinker	Feinsteinzeug, Einbrandfliese (Keramikfliesen), Klinker	Grès vitrifié, céramique monocuissons, klinker	★★★★
Piastrelle in granito e pietre dure, cotto	Granitfliesen und Harter Stein, Cotto	Carreaux de granit et de la pierre dure, brique	★★★★
Piastrelle in marmo	Marmorfliesen	Carreaux de marbre	★★★★☆

# SCX-F - Sandwich Tech



**DNA 4<sup>TH</sup>**

Gres porcellanato/Ceramica/Marmo/Granito  
Feinsteinzeug/Keramik/Marmor/Granit  
Grès vitrifié/Céramique/Marbre/Granit

GOLD LINE  
"HIGH TECHNOLOGY"



10 mm

Art.	Ø		Ø	
	mm	inch	mm *	mm
SCX-F250	250	10	30/25,4	2,2
SCX-F300	300	12	30/25,4	2,4
SCX-F350	350	14	30/25,4	2,4
SCX-F350/60	350	14	60/50	2,4

\* 5/8 inch: Riduzione a richiesta • Reduzierung auf Anfrage • Réduction sur demande

Velocità - Geschwindigkeit - Vitesse	Durata - Dauer - Durée	Finitura - Endbearbeitung - Finition
★★★★☆	★★★★☆	★★★★

IT	DE	FR	
Gres porcellanato	Feinsteinzeug	Grès vitrifié	★★★★
Gres porcellanato duro	Harter-Feinsteinzeug	Grès vitrifié tres dure	★★★★☆
Piastrelle in monocottura, klinker, cotto	Einbrandfliese (Keramikfliesen), Klinker, Cotto	Céramique monocuissons, klinker, brique	★★★★
Piastrelle in granito, pietre dure, marmo	Granitfliesen und Harter Stein, Marmor	Carreaux de granit et de la pierre dure, marbre	★★★★
Piastrelle in bicottura	Doppelbrand Keramikfliesen	Céramique bicuisson	★★★★☆

# CBX - CONTINUOUS RIM

Gres porcellanato/Granito  
Feinsteinzeug/Granit  
Grès vitrifié/Granit



**DNA 4<sup>TH</sup>**



GOLD LINE  
"HIGH TECHNOLOGY"



Velocità - Geschwindigkeit - Vitesse	Durata - Dauer - Durée	Finitura - Endbearbeitung - Finition
★★★★★	★★★★★	★★★★☆

Art.	Ø		Ø	
	mm	inch	mm*	mm
CBX100 *	100	4	22,2/15,8	1,3
CBX115 *	115	4,5	22,2	1,3
CBX125 *	125	5	22,2	1,3
CBX230	230	9	22,2	2,0

\* 5/8 inch: Riduzione a richiesta • Reduzierung auf Anfrage • Réduction sur demande

\* **XLOCK**: A richiesta • Auf Anfrage • Sur demande

IT	DE	FR	
Gres porcellanato, klinker, monocottura	Feinsteinzeug, Klinker, Einbrandfliese (Keramikfliesen)	Grès vitrifié, klinker, céramique monocuissons	★★★★★
Piastrelle in granito e pietra naturale	Granitfliesen und Naturstein	Carreaux de granit et de la pierre naturelle	★★★★★
Lastre sottili in gres porcellanato	Feinsteinzeugplatten dünn	Dalles de grès cérame mince	★★★★☆
Gres porcellanato alto spessore	Dickes Feinsteinzeug	Grès cérame à haute épaisseur	★★★★☆
Piastrelle in bicottura, piastrelle in marmo	Doppelbrand Keramikfliesen, Marmorfliesen	Céramique bicoisson, carreaux de marbre	★★★★☆

# TXH - TURBO

Granito/Pietre dure/Calcestruzzo/Edilizia  
Granit/Harter Stein/Beton/Bau Industrie  
Granit/Pierre dure/Béton/Batiment



**DNA 4<sup>TH</sup>**



GOLD LINE  
"HIGH TECHNOLOGY"

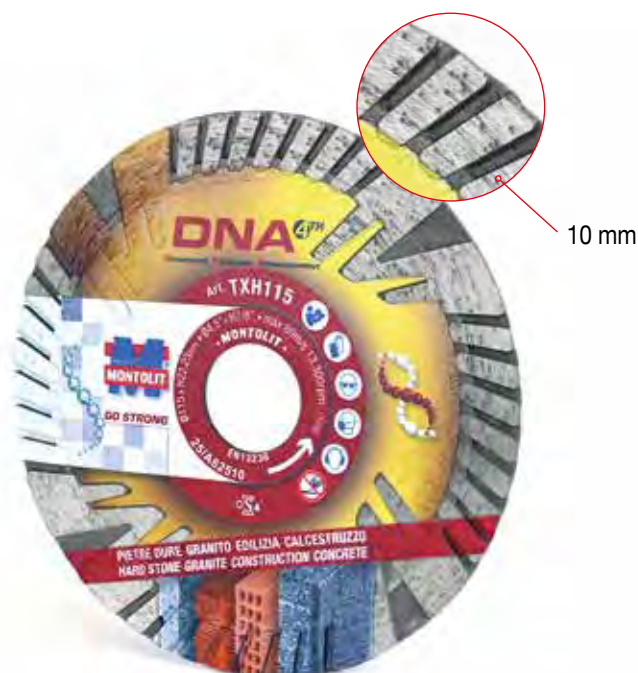

Velocità - Geschwindigkeit - Vitesse	Durata - Dauer - Durée	Finitura - Endbearbeitung - Finition
★★★★☆	★★★★★	★★★★☆

Art.	Ø		Ø	
	mm	inch	mm*	mm
TXH115	115	4,5	22,2	2,4
TXH230	230	9	22,2	2,8

\* 5/8 inch: Riduzione a richiesta • Reduction on request • Reducción a pedido

IT	DE	FR	
Tegole, laterizio, mattoni	Dachziegel, Mauerziegel	Tuiles, brique	★★★★★
Autobloccanti, arenaria, refrattario	Betonstein, Sandstein, Schamottestein	Briques autobloquants, grès, réfractaire	★★★★★
Granito, pietra, porfido	Granit, Stein, Porphyre	Granit, pierre, porphyre	★★★★★
Calcestruzzo, calcestruzzo armato	Beton, Stahlbeton	Béton, béton armé	★★★★☆
Marmo, ceramica	Marmor, Keramikfliesen	Marbre, céramique	★★★☆☆

# CGX - CONTINUOUS RIM

**NEW**

**DNA 4<sup>TH</sup>**

Gres porcellanato/Ceramica dura  
Feinsteinzeug/Harte Keramikfliesen  
Grès vitrifié/Céramique compacte



**GOLD LINE**  
"HIGH TECHNOLOGY"

Velocità - Geschwindigkeit - Vitesse	Durata - Dauer - Durée	Finitura - Endbearbeitung - Finition
★★★★	★★★☆☆	★★★★☆



**TOP SPEED**

Super veloce  
Superschnell  
Super rapide

Art.	Ø		Ø		Ø	
	mm	inch	mm*	mm	mm	mm
CGX100	100	4	22,2/15,8	1,3		
CGX115	115	4,5	22,2	1,3		
CGX125	125	5	22,2	1,3		

\* 5/8 inch: Riduzione a richiesta • Reduzierring auf Anfrage • Réduction sur demande

IT	DE	FR	
Gres porcellanato, klinker, monocottura	Feinsteinzeug, Klinker, Einbrandfliese (Keramikfliesen)	Grès vitrifié, klinker, céramique monocuissons	★★★★★
Piastrelle in granito e pietra naturale	Granitfliesen und Naturstein	Carreaux de granit et de la pierre naturelle	★★★★★
Lastre sottili in gres porcellanato	Feinsteinzeugplatten dünn	Dalles de grès cérame mince	★★★★☆
Gres porcellanato alto spessore	Dickes Feinsteinzeug	Grès cérame à haute épaisseur	★★★★☆
Piastrelle delicate, piastrelle in marmo	Empfindliche Fliesen, Marmorfliesen	Céramique délicates, carreaux de marbre	★★★★☆

# LX - LASER

Calcestruzzo/Edilizia/Granito/Pietre dure  
Beton/Bau Industrie/Granit/Porphyr/Harter Stein  
Béton/Batiment/Granit/Porphyre/Pierre dure



**DNA 4<sup>TH</sup>**



**GOLD LINE**  
"HIGH TECHNOLOGY"

Velocità - Geschwindigkeit - Vitesse	Durata - Dauer - Durée	Finitura - Endbearbeitung - Finition
★★★★	★★★★☆	★★★☆☆

Art.	Ø		Ø		
	mm	inch	mm *	mm	
LX115	115	4,5	22,2	2,2	
LX125	125	5	22,2	2,2	
LX150	150	6	22,2	2,2	
LX180	180	7	22,2	2,2	
LX230	230	9	22,2	2,6	

\* 5/8 inch: Riduzione a richiesta • Reduzierring auf Anfrage • Réduction sur demande

IT	DE	FR	
Calcestruzzo, autobloccanti	Beton, Betonstein	Béton, briques autobloquants	★★★★★
Calcestruzzo armato	Stahlbeton	Béton armé	★★★★★
Granito, pietra, porfido	Granit, Stein, Porphy	Granit, pierre, porphyre	★★★★★
Tegole, laterizio, mattoni	Dachziegel, Mauerziegel	Tuiles, brique	★★★★★
Arenaria, refrattario	Sandstein, Schamottestein	Grès, réfractaire	★★★★☆

# LXS - LASER SILENT

Calcestruzzo/Edilizia/Granito/Pietre dure  
Beton/Bau Industrie/Granit/Porphyr/Harter Stein  
Béton/Batiment/Granit/Porphyre/Pierre dure

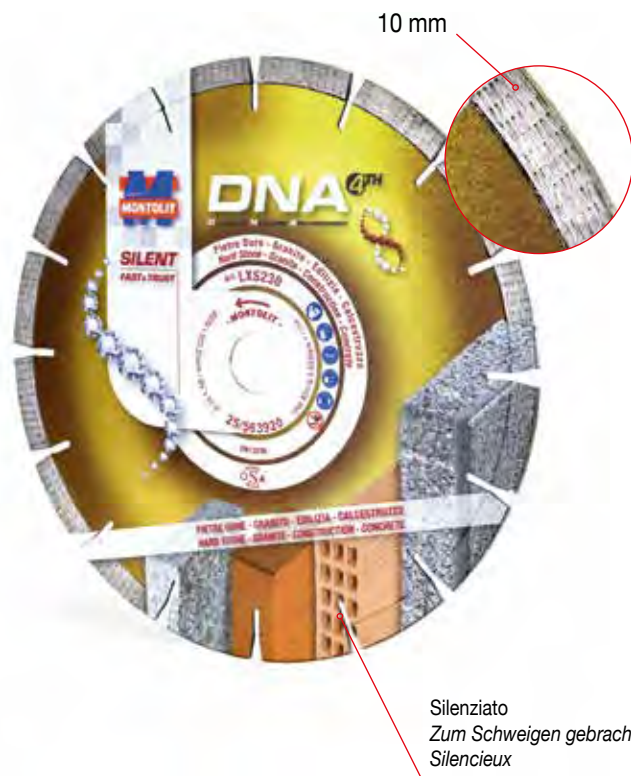

**DNA 4<sup>TH</sup>**



**GOLD LINE**  
"HIGH TECHNOLOGY"

Velocità - Geschwindigkeit - Vitesse	Durata - Dauer - Durée	Finitura - Endbearbeitung - Finition
★★★★	★★★★☆	★★★☆☆

Art.	Ø		Ø		
	mm	inch	mm *	mm	
LXS230	230	9	22,2	2,6	

\* 5/8 inch: Riduzione a richiesta • Reduzierring auf Anfrage • Réduction sur demande

IT	DE	FR	
Calcestruzzo, autobloccanti	Beton, Betonstein	Béton, briques autobloquants	★★★★★
Calcestruzzo armato	Stahlbeton	Béton armé	★★★★★
Granito, pietra, porfido	Granit, Stein, Porphy	Granit, pierre, porphyre	★★★★★
Tegole, laterizio, mattoni	Dachziegel, Mauerziegel	Tuiles, brique	★★★★★
Arenaria, refrattario	Sandstein, Schamottestein	Grès, réfractaire	★★★★☆

# LX - LASER



**DNA 4<sup>TH</sup>**

Calcestruzzo/Edilizia/Granito/Pietre dure  
Beton/Bau Industrie/Granit/Porphyr/Harter Stein  
Béton/Batiment/Granit/Porphyre/Pierre dure



GOLD LINE  
"HIGH TECHNOLOGY"

13 mm

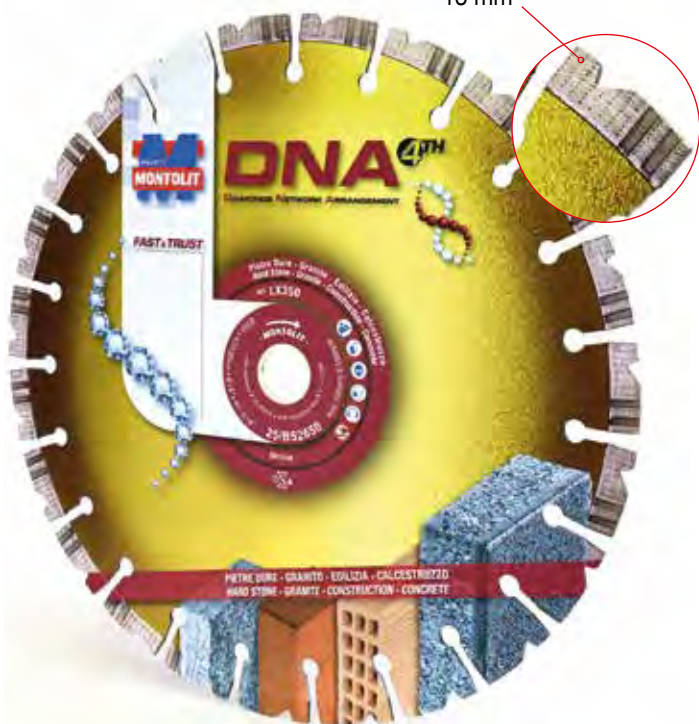

Velocità - Geschwindigkeit - Vitesse	Durata - Dauer - Durée	Finitura - Endbearbeitung - Finition
★★★★	★★☆☆	★★☆☆

Art.	Ø		Ø	
	mm	inch	mm *	mm
LX250	250	10	30/25,4	2,6
LX300	300	12	30/25,4	3,2
LX350	350	14	30/25,4	3,2
LX400	400	16	30/25,4	3,2
LX600	600	24	60/50/25,4	4,0
LX650	650	26	60/50/25,4	4,0
LX720	720	29	60/50/25,4	4,0

\* 5/8 inch: Riduzione a richiesta • Reduzierung auf Anfrage • Réduction sur demande

IT	DE	FR	
Calcestruzzo armato	Stahlbeton	Béton armé	★★★★★
Tegole, laterizio, mattoni	Dachziegel, Mauerziegel	Tuiles, brique	★★★★★
Calcestruzzo, autobloccanti	Beton, Betonstein	Béton, briques autobloquants	★★★★☆
Granito, pietra, porfido	Granit, Stein, Porphy	Granit, pierre, porphyre	★★★★☆
Arenaria, refrattario	Sandstein, Schamottestein	Grès, réfractaire	★★★☆☆

# LXS - LASER SILENT



**DNA 4<sup>TH</sup>**

Calcestruzzo/Edilizia/Granito/Pietre dure  
Beton/Bau Industrie/Granit/Porphyr/Harter Stein  
Béton/Batiment/Granit/Porphyre/Pierre dure



GOLD LINE  
"HIGH TECHNOLOGY"

10 mm



Velocità - Geschwindigkeit - Vitesse	Durata - Dauer - Durée	Finitura - Endbearbeitung - Finition
★★★★★	★★★★☆	★★★☆☆

Art.	Ø		Ø	
	mm	inch	mm	mm
LXS350	350	14	30/25,4	3,2

IT	DE	FR	
Calcestruzzo armato	Stahlbeton	Béton armé	★★★★★
Tegole, laterizio, mattoni	Dachziegel, Mauerziegel	Tuiles, brique	★★★★★
Calcestruzzo, autobloccanti	Beton, Betonstein	Béton, briques autobloquants	★★★★☆
Granito, pietra, porfido	Granit, Stein, Porphy	Granit, pierre, porphyre	★★★★☆
Arenaria, refrattario	Sandstein, Schamottestein	Grès, réfractaire	★★★☆☆

# LXR - LASER

Calcestruzzo/Edilizia/Materiali abrasivi/Granito  
 Beton/Bau Industrie/Schleifmittel/Granit  
 Béton/Batiment/Matériaux abrasifs/Granit

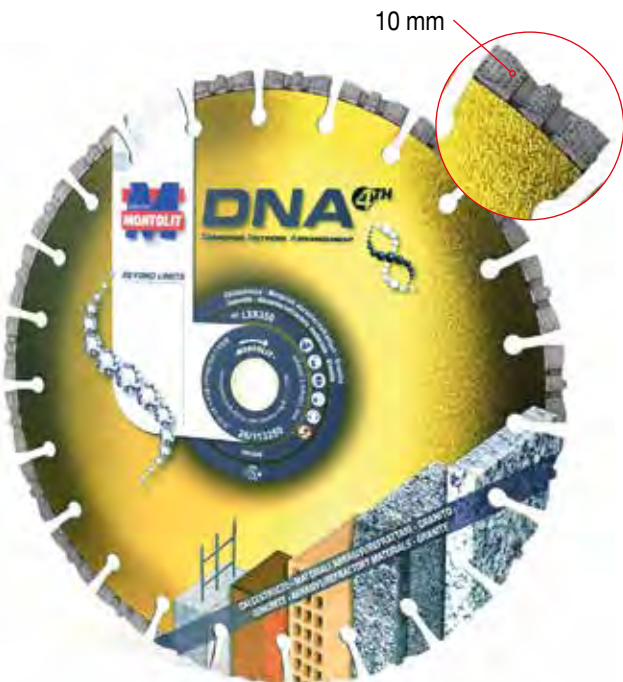

**DNA 4<sup>TH</sup>**



GOLD LINE  
 "HIGH TECHNOLOGY"

Velocità - Geschwindigkeit - Vitesse	Durata - Dauer - Durée
★★★★	★★★★

Art.	Ø		Ø	
	mm	inch	mm	mm
LXR300	300	12	30/25,4	3,0
LXR350	350	14	30/25,4	3,0
LXR400	400	16	30/25,4	3,0

IT	DE	FR	
Tegole in cemento, autobloccanti	Beton-Dachpfannen, Betonstein	Tuiles en béton, briques autobloquants	★★★★
Laterizio, mattoni, mattoni abrasivi	Mauerziegel, Schleif Ziegel	Brique, briques abrasives	★★★★
Arenaria, lastre ghiaino lavato	Sandstein, Kies gewaschen Platten	Grès, dalles de graviers lavés	★★★★
Calcestruzzo, calcestruzzo armato	Beton, Stahlbeton	Béton, béton armé	★★★★☆
Granito, pietra, porfido	Granit, Stein, Porphyr	Granit, pierre, porphyre	★★★☆☆

# LXA - LASER

Calcestruzzo/Asfalto (Per macchine di bassa/media potenza - max 5kW)  
 Beton/Asphalt (Für Maschinen mit niedriger Leistung - max 5kW)  
 Béton/Asphalte (Pour machines à faible puissance - max 5kW)



**DNA 4<sup>TH</sup>**



GOLD LINE  
 "HIGH TECHNOLOGY"

Velocità - Geschwindigkeit - Vitesse	Durata - Dauer - Durée
★★★★	★★★★☆

Art.	Ø		Ø	
	mm	inch	mm	mm
LXA350	350	14	30/25,4	3,2
LXA400	400	16	30/25,4	3,2
LXA450	450	18	30/25,4	3,2

IT	DE	FR	
Asfalto	Asphalt	Asphalte	★★★★
Pavimentazione in calcestruzzo fresco	Straßendecke aus Frischbeton	Pavage en béton frais	★★★★☆
Pavimentazione in calcestruzzo	Straßendecke aus Beton	Pavage en béton	★★★☆☆

# SX - LASER

**DNA EVO3**

Pavimenti in calcestruzzo stagionato  
 Straßendecke aus gelagertem Beton  
 Pavage en béton vieux



GOLD LINE  
 "HIGH TECHNOLOGY"

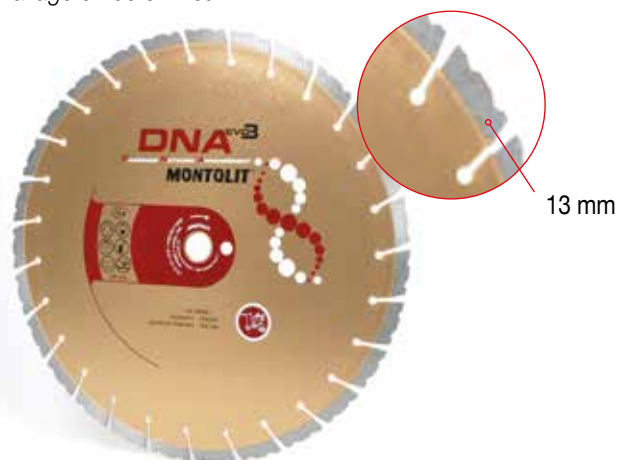

Velocità - Geschwindigkeit - Vitesse	Durata - Dauer - Durée
★★★★	★★★★

Art.	Ø		Ø		
	mm	inch	mm	mm	
SX350	350	14	30/25,4	2,8	
SX400	400	16	30/25,4	3,2	
SX450	450	18	30/25,4	3,2	
SX500	500	20	30/25,4	4,0	

# SXF - LASER

**DNA EVO3**

Pavimenti in calcestruzzo fresco  
 Straßendecke aus Frischbeton  
 Pavage en béton frais



GOLD LINE  
 "HIGH TECHNOLOGY"

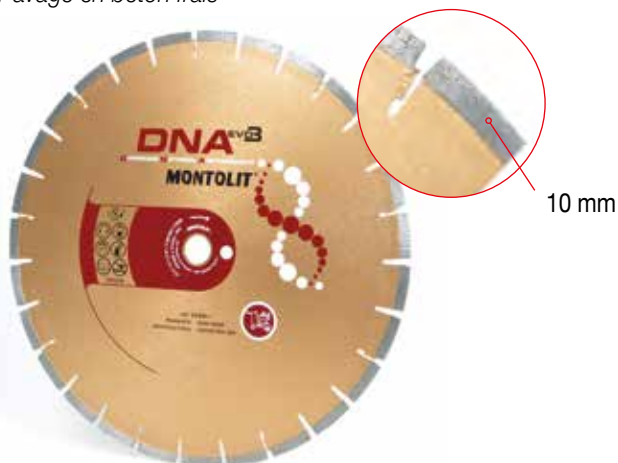

Velocità - Geschwindigkeit - Vitesse	Durata - Dauer - Durée
★★★★	★★★★☆

Art.	Ø		Ø		
	mm	inch	mm	mm	
SXF350	350	14	30/25,4	3,2	
SXF400	400	16	30/25,4	3,2	
SXF450	450	18	30/25,4	3,2	

# SXA - LASER

**DNA EVO3**

Asfalto  
 Asphalt  
 Asphalt



GOLD LINE  
 "HIGH TECHNOLOGY"

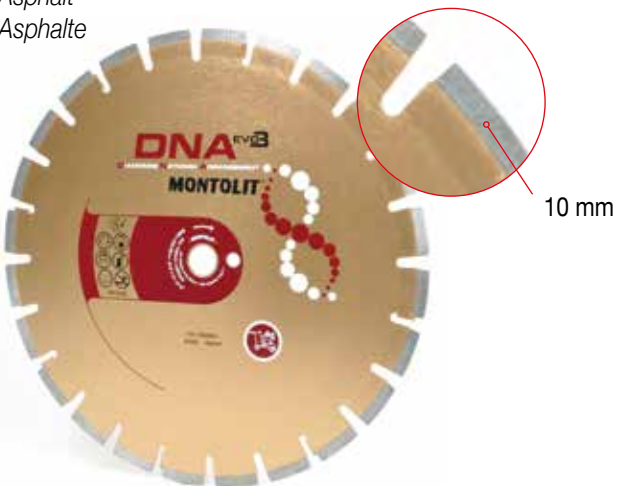

Velocità - Geschwindigkeit - Vitesse	Durata - Dauer - Durée
★★★★	★★★★☆

Art.	Ø		Ø		
	mm	inch	mm	mm	
SXA400	400	16	30/25,4	3,2	
SXA450	450	18	30/25,4	3,6	
SXA500	500	20	30/25,4	3,6	

**MONTOLIT**

# FX - LASER



**DNA 4<sup>TH</sup>**

Calcestruzzo/Calcestruzzo armato/Materiali edili  
 Beton/Stahlbeton/Bau Industrie  
 Béton/ Béton armé/Batiment



**GOLD LINE**  
 "HIGH TECHNOLOGY"

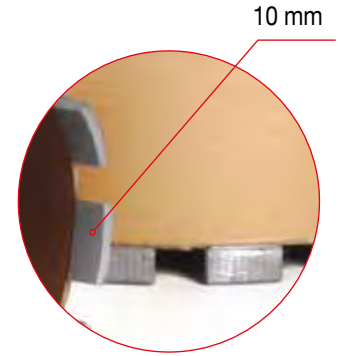

pg. 44 → Accessori  
 Zubehör  
 Accessoires

Art.	Ø		n°	mm	n° giri RPM	Potenza consigliata Empfohlene Leistung Puissance recommandée	
	mm	inch				W min	W max
FX 32	32	1-1/4"	4	450	800 ÷ 1.800	1.200	1.800
FX 36	36	1-7/16	4	450	700 ÷ 1.700	1.200	1.800
FX 42	42	1-5/8	5	450	700 ÷ 1.700	1.200	1.800
FX 47	47	1-7/8	5	450	600 ÷ 1.500	1.200	1.800
FX 52	52	2-1/16	4	450	500 ÷ 1.300	1.200	1.800
FX 62	62	2-7/16	5	450	450 ÷ 1.100	1.200	1.800
FX 82	82	3-1/4	7	450	350 ÷ 800	1.200	2.200
FX 92	92	3-5/8	7	450	320 ÷ 720	1.200	2.200
FX102	102	4	8	450	280 ÷ 650	1.200	2.200
FX112	112	4-7/16	9	450	250 ÷ 600	1.800	2.500
FX122	122	4-3/4	10	450	230 ÷ 550	1.800	2.500
FX127	127	5	11	450	230 ÷ 550	1.800	2.500
FX132	132	5-3/16	11	450	230 ÷ 550	1.800	2.500
FX142	142	5-5/8	11	450	230 ÷ 550	1.800	2.500
FX152	152	6	12	450	200 ÷ 500	1.800	2.500
FX162	162	6-3/8	12	450	180 ÷ 450	1.800	2.500
FX182	182	7-3/16	14	450	150 ÷ 380	2.000	3.000
FX202	202	8	15	450	150 ÷ 380	2.000	3.300
FX225	225	8-7/8	15	450	150 ÷ 380	2.000	3.300
FX250	250	9-7/8	18	450	150 ÷ 380	2.000	3.300

**VELOCITÀ CONSIGLIATA  
 EMPFOHLENE GESCHWINDIGKEIT  
 VITESSE RECOMMANDÉE**

Materiale tenero Weiches Material Matériau doux	3-4 m/s
Materiale medio Mittleres Material Matériau moyens	2-3 m/s
Materiale duro Hartes Material Matériau dur	1,5-2 m/s

# FUXLT - TURBO LASER



Calcestruzzo/Calcestruzzo armato/Laterizio/Mattoni abrasivi/  
Autobloccanti  
Beton/Stahlbeton/Mauerziegel/Kalksandstein und Betonstein  
Béton/Béton armé/Briques/Briques abrasifs et autobloquants



Corpo conico - Massima velocità  
Konischer Körper - Maximale Geschwindigkeit  
Corps conique - Vitesse maximale

Saldatura laser, utilizzo a secco  
Lasergeschweißt, trockener Einsatz  
Soudage laser, utilisation à sec

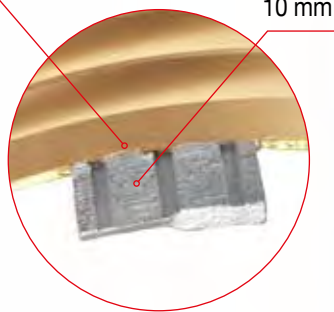

DNA SPECIAL TURBO massime prestazioni  
SPECIAL TURBO DNA maximale Leistung  
DNA SPECIAL TURBO performances maximales



Attacco 1-1/4" imbocco largo  
max asportazione polveri  
Anschluss 1-1/4" - breite Öffnung,  
maximale Staubabsaugung  
Raccordement 1-1/4" - orifice large,  
dépoussiérage maximal

Corpo spiralato  
rimozione polvere agevolata  
Spiralförmiger Körper, einfache  
Staubentfernung  
Corps spiralé facilitant le  
dépoussiérage



pg. 44 → Accessori  
Zubehör  
Accessoires

VELOCITÀ CONSIGLIATA  
EMPFOHLENE GESCHWINDIGKEIT  
VITESSE RECOMMANDÉE

Materiale tenero Weiches Material Matériau doux	3-4 m/s
Materiale medio Mittleres Material Matériau moyens	2-3 m/s
Materiale duro Hartes Material Matériau dur	1,5-2 m/s

Art.	Ø		n°	mm	n° giri RPM	Potenza consigliata Empfohlene Leistung Puissance recommandée	
	mm	inch				W min	W max
FUXLT 32	32	1-1/4"	3	300	800 ÷ 1.800	1.200	1.800
FUXLT 42	42	1-5/8"	3	300	700 ÷ 1.700	1.200	1.800
FUXLT 52	52	2-1/16"	3	300	500 ÷ 1.300	1.200	1.800
FUXLT 62	62	2-7/16"	3	300	450 ÷ 1.100	1.200	1.800
FUXLT 68	68	2-11/16"	3	300	400 ÷ 900	1.200	2.200
FUXLT 82	82	3-1/4"	4	300	350 ÷ 800	1.200	2.200
FUXLT102	102	4"	5	300	280 ÷ 650	1.200	2.200
FUXLT112	112	4-7/16"	6	300	250 ÷ 600	1.800	2.500
FUXLT127	127	5"	6	300	230 ÷ 550	1.800	2.500
FUXLT162	162	6-3/8"	8	300	180 ÷ 450	1.800	2.500

# FUXT - LASER



**DNA 4<sup>TH</sup>**

Calcestruzzo/Calcestruzzo armato/Laterizio/Mattoni abrasivi/Autobloccanti  
 Beton/Stahlbeton/Mauerziegel/KalkSandstein und Betonstein  
 Béton/Béton armé/Briques/Briques abrasifs et autobloquants



**GOLD LINE**  
"HIGH TECHNOLOGY"

Attacco M16  
Anschluss M16  
Raccordement M16

Corpo conico - Massima velocità  
Konischer Körper - Maximale Geschwindigkeit  
Corps conique - Vitesse maximale

DNA SPECIAL TURBO massime prestazioni  
SPECIAL TURBO DNA maximale Leistung  
DNA SPECIAL TURBO performances maximales

Asole speciali rimozione polvere agevolata  
Spezial-Knopföcher, einfache Staubentfernung  
Boutonnieres spéciales facilitant le dépoussiérage

10 mm

Saldatura laser, utilizzo a secco  
Lasergeschweißt, trockener Einsatz  
Soudage laser, utilisation à sec

Corpo spiralato  
rimozione polvere agevolata  
Spiralförmiger Körper, einfache  
Staubentfernung  
Corps spiralé facilitant le  
dépoussiérage



Art.	Ø		n°	mm	n° giri RPM	Potenza consigliata Empfohlene Leistung Puissance recommandée	
	mm	inch				W min	W max
FUXT 32	32	1-1/4	M16	3	150	800 ÷ 1.800	1.200 1.800
FUXT 36	36	1-7/16	M16	3	150	700 ÷ 1.700	1.200 1.800
FUXT 42	42	1-5/8	M16	3	150	700 ÷ 1.700	1.200 1.800
FUXT 47	47	1-7/8	M16	3	150	600 ÷ 1.500	1.200 1.800
FUXT 52	52	2-1/16	M16	3	150	500 ÷ 1.300	1.200 1.800
FUXT 57	57	2-1/4	M16	3	150	450 ÷ 1.200	1.200 1.800
FUXT 62	62	2-7/16	M16	3	150	450 ÷ 1.100	1.200 1.800
FUXT 68	68	2-11/16	M16	4	150	400 ÷ 900	1.200 2.200
FUXT 82	82	3-1/4	M16	4	150	350 ÷ 800	1.200 2.200
FUXT 92	92	3-5/8	M16	4	150	320 ÷ 720	1.200 2.200
FUXT102	102	4	M16	5	150	280 ÷ 650	1.200 2.200
FUXT112	112	4-7/16	M16	5	150	250 ÷ 600	1.800 2.500
FUXT127	127	5	M16	6	150	230 ÷ 550	1.800 2.500
FUXT132	132	5-3/16	M16	7	150	230 ÷ 550	1.800 2.500
FUXT142	142	5-5/8	M16	7	150	230 ÷ 550	1.800 2.500
FUXT152	152	6	M16	7	150	200 ÷ 500	1.800 2.500
FUXT162	162	6-3/8	M16	8	150	180 ÷ 450	1.800 2.500
FUXT182	182	7-3/16	M16	9	150	150 ÷ 380	2.000 3.000
FUXT202	202	8	M16	9	150	150 ÷ 380	2.000 3.000

pg. 107 → Espositore  
Austellmodul  
Affichage

pg. 44 → Accessori  
Zubehör  
Accessoires

**VELOCITÀ CONSIGLIATA  
EMPFOHLENE GESCHWINDIGKEIT  
VITESSE RECOMMANDÉE**

Materiale tenero Weiches Material Matériau doux	3-4 m/s
Materiale medio Mittleres Material Matériau moyens	2-3 m/s
Materiale duro Hartes Material Matériau dur	1,5-2 m/s

# FUTS - SPIRAL TURBO

Calcestruzzo/Calcestruzzo armato/Laterizio/Mattoni abrasivi/Autobloccanti  
 Beton/Stahlbeton/Mauerziegel/Kalksandstein und Betonstein  
 Béton/Béton armé/Briques/Briques abrasifs et autobloquants



Attacco M16  
 Anschluss M16  
 Raccordement M16

Corpo spiralato  
 rimozione polvere agevolata  
 Spiralförmiger Körper,  
 einfache Staubentfernung  
 Corps spiralé facilitant le  
 dépeussierage

12 mm

Asole speciali rimozione  
 polvere agevolata  
 Spezial-Knopflöcher, einfache  
 Staubentfernung  
 Boutonnères spéciales  
 facilitant le dépeussierage

Saldatura laser, utilizzo a secco  
 Lasergeschweißt, trockener Einsatz  
 Soudage laser, utilisation à sec



Art. n° giri RPM Potenza consigliata  
 Empfohlene Leistung  
 Puissance recommandée

Art.	mm	inch	M16	n°	mm	n° giri RPM	W min	W max
FUTS 32	32	1-1/4	M16	3	150	800 ÷ 1.800	1.200	1.800
FUTS 36	36	1-7/16	M16	3	150	700 ÷ 1.700	1.200	1.800
FUTS 42	42	1-5/8	M16	3	150	700 ÷ 1.700	1.200	1.800
FUTS 47	47	1-7/8	M16	3	150	600 ÷ 1.500	1.200	1.800
FUTS 52	52	2-1/16	M16	3	150	500 ÷ 1.300	1.200	1.800
FUTS 57	57	2-1/4	M16	3	150	450 ÷ 1.200	1.200	1.800
FUTS 62	62	2-7/16	M16	3	150	450 ÷ 1.100	1.200	1.800
FUTS 68	68	2-11/16	M16	4	150	400 ÷ 900	1.200	2.200
FUTS 82	82	3-1/4	M16	4	150	350 ÷ 800	1.200	2.200
FUTS 92	92	3-5/8	M16	4	150	320 ÷ 720	1.200	2.200
FUTS102	102	4	M16	5	150	280 ÷ 650	1.200	2.200
FUTS112	112	4-7/16	M16	5	150	250 ÷ 600	1.800	2.500
FUTS127	127	5	M16	6	150	230 ÷ 550	1.800	2.500
FUTS132	132	5-3/16	M16	6	150	230 ÷ 550	1.800	2.500
FUTS152	152	6	M16	7	150	200 ÷ 500	1.800	2.500
FUTS162	162	6-3/8	M16	8	150	180 ÷ 450	1.800	2.500
FUTS182	182	7-3/16	M16	8	150	150 ÷ 380	2.000	3.000
FUTS202	202	8	M16	9	150	150 ÷ 380	2.000	3.300

pg.  
44

Accessori  
 Zubehör  
 Accessoires

VELOCITÀ CONSIGLIATA  
 EMPFOHLENE GESCHWINDIGKEIT  
 VITESSE RECOMMANDÉE

Materiale tenero Weiches Material Matériau doux	3-4 m/s
Materiale medio Mittleres Material Matériau moyens	2-3 m/s
Materiale duro Hartes Material Matériau dur	1,5-2 m/s

# CM - CONTINUOUS RIM

Mosaico vetroso e/o in pietra naturale/Ceramica sottile e delicata  
 Glas- und Naturstein Mosaik/Dünne und Empfindliche Keramikleile  
 Mosaïque en pâte de verre et en pierre naturelle/Grès émaillé mince et délicat



SILVER LINE  
"TOP"



10 mm

Massima finitura - Velocità ridotta - Non forzare  
 Maximales finish - Reduzierte Geschwindigkeit - Ohne Druck  
 Finition maximale - Vitesse réduite - Ne forcez pas

Velocità - Geschwindigkeit - Vitesse	Durata - Dauer - Durée	Finitura - Endbearbeitung - Finition
★★★★☆	★★★★☆	★★★★★

Art.				
	mm	inch	mm*	mm
CM100	100	4	22,2	1,2
CM115	115	4,5	22,2	1,2
CM125	125	5	22,2	1,2

\* 5/8 inch: Riduzione a richiesta • Reduzierung auf Anfrage • Réduction sur demande

IT	DE	FR	
Mosaico vetroso	Glasmosaik	Mosaïque en pâte de verre	★★★★★
Mosaico in gres porcellanato	Feinsteinzeugmosaik	Le grès cérame mosaïque	★★★★★
Mosaico in pietra naturale	Natursteinmosaik	Mosaïque en pierre naturelle	★★★★★
Lastre sottili in gres porcellanato	Feinsteinzeugplatten schlank	Dalles de grès cérame mince	★★★★★
Piastrelle in bicottura, piastrelle delicate	Doppelbrand Keramikfliesen, empfindliche Fliesen	Céramique bicoisson, céramique délicates	★★★★☆

# CSS - ULTRATHIN

Lastre sottili in gres porcellanato  
 Dünne Feinsteinzeugplatten  
 Plaques minces en grès cérame



7 mm



Massima finitura - Velocità ridotta - Non forzare  
 Maximales finish - Reduzierte Geschwindigkeit - Ohne Druck  
 Finition maximale - Vitesse réduite - Ne forcez pas

Velocità - Geschwindigkeit - Vitesse	Durata - Dauer - Durée	Finitura - Endbearbeitung - Finition
★★★★☆	★★★★☆	★★★★★

Art.				
	mm	inch	mm	mm
<b>NEW</b> CSS76	76	3	10	0,8
CSS100 *	100	4	22,2	1,0
<b>NEW</b> CSS115 *	115	4,5	22,2	1,1
<b>NEW</b> CSS125 *	125	5	22,2	1,1
<b>NEW</b> CSS150	150	6	30	1,1

CSS100-T-U \* N° 1 art. CSS100 + N° 1 art. TUTORCUT115-U

\* 5/8 inch: Riduzione a richiesta • Reduzierung auf Anfrage • Réduction sur demande

IT	DE	FR	
Lastre sottili in gres porcellanato	Feinsteinzeugplatten schlank	Dalles de grès cérame mince	★★★★★
Piastrelle con smalto vetroso	Fliesen mit Glas Emaille	Carreaux avec émail vitreux	★★★★★
Piastrelle in bicottura	Doppelbrand Keramikfliesen	Céramique bicoisson	★★★★★
Piastrelle in monocottura	Einbrandfliese (Keramikfliesen)	Céramique monocuissions	★★★★☆

# CG - CONTINUOUS RIM

Gres porcellanato/Ceramica dura  
Feinsteinzeug/Harte Keramikfliesen  
Grès vitrifié/Céramique compacte



RED LINE  
"PROFESSIONAL"

Velocità - Geschwindigkeit - Vitesse	Durata - Dauer - Durée	Finitura - Endbearbeitung - Finition
★★★★	★★★★☆	★★★★☆

Art.						
	mm	inch	mm*	mm	mm	mm
CG115	115	4,5	22,2	1,4		
CG125	125	5	22,2	1,4		
CG230	230	9	22,2	2,0		

\* 5/8 inch: Riduzione a richiesta • Reduzierring auf Anfrage • Réduction sur demande

IT	DE	FR	
Gres porcellanato, klinker, monocottura	Feinsteinzeug, klinker, Einmalbrand (Keramikfliesen)	Grès vitrifié, klinker, céramique monocuissons	★★★★★
Lastre sottili in gres porcellanato	Feinsteinzeugplatten schlank	Dalles de grès cérame mince	★★★★★
Gres porcellanato alto spessore	Feinsteinzeug hohe Dicke	Grès cérame à haute épaisseur	★★★★★
Piastrelle in granito e pietra naturale	Granitfliesen und Naturstein	Carreaux de granit et de la pierre naturelle	★★★★☆
Piastrelle delicate, piastrelle in marmo	Empfindliche Fliesen, Marmorfliesen	Céramique délicates, carreaux de marbre	★★★★☆

# CSE - CONTINUOUS RIM

Ceramica/Gres porcellanato  
Keramikfliesen/Feinsteinzeug  
Céramique/Grès vitrifié



BLU LINE  
"UNIVERSAL"

Velocità - Geschwindigkeit - Vitesse	Durata - Dauer - Durée	Finitura - Endbearbeitung - Finition
★★★★☆	★★★★☆	★★★★☆

Art.						
	mm	inch	mm*	mm	mm	mm
CSE115	115	4,5	22,2	1,6		
CSE230P	230	9	22,2	2,0		

\* 5/8 inch: Riduzione a richiesta • Reduzierring auf Anfrage • Réduction sur demande

IT	DE	FR	
Gres porcellanato	Feinsteinzeug	Grès vitrifié	★★★★★
Piastrelle in monocottura, cotto	Einbrandfliese (Keramikfliesen), Cotto	Céramique monocuissons, brique	★★★★★
Piastrelle in granito e pietre naturali	Granitfliesen und Naturstein	Carreaux de granit et de la pierre naturelle	★★★★☆
Piastrelle in bicottura, piastrelle in marmo	Doppelbrand Keramikfliesen, Marmorfliesen	Céramique bicuisson, carreaux de marbre	★★★★☆
Piastrelle con smalto vetroso	Fliesen mit Glas Emaille	Carreaux avec émail vitreux	★★★★☆

# MINI - Ø 50 mm



**Art. STL50GF**

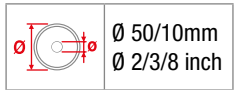

· Mola diamantata grana fine per taglio e levigatura di gres porcellanato, ceramica delicata, marmo.  
 · Feinkörnige Diamant-Schleifscheibe zum Schneiden und Schleifen von Feinsteinzeug, empfindlicher Keramik und Marmor.  
 · Meule diamantée à grain fin pour la découpe et le ponçage du grès cérame, des céramiques délicates et du marbre.



**Art. MINIFLEXIMONT-GG**

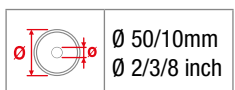

· Disco diamantato lamellare grana grossa per gres porcellanato, ceramica, granito, marmo e vetro.  
 · Lamellen-Diamantscheibe mit grober Körnung für Feinsteinzeug, Keramik, Granit, Marmor und Glas.  
 · Disque diamanté à lamelles à gros grain pour le grès cérame, la céramique, le granit, le marbre et le verre.



**Art. MINIFLEXIMONT-GM**

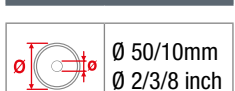

· Disco diamantato lamellare grana media per gres porcellanato, ceramica, granito, marmo e vetro.  
 · Lamellen-Diamantscheibe mit mittlerer Körnung für Feinsteinzeug, Keramik, Granit, Marmor und Glas.  
 · Disque diamanté à lamelles à moyen grain pour le grès cérame, la céramique, le granit, le marbre et le verre.



# MIDI - Ø 76 mm



**Art. CSS76**

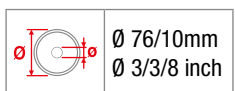

· Disco diamantato supersottile (0,8mm) a fascia continua per gres porcellanato, ceramica delicata, marmo.  
 · Ultradünne Diamantscheibe (0,8 mm) mit geschlossenem Rand für Feinsteinzeug, empfindliche Keramik und Marmor.  
 · Disque diamanté ultra-fin (0,8 mm) à jante continue pour le grès cérame, la céramique délicate et le marbre.



**Art. TCS76**

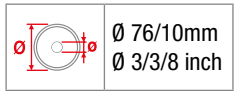

· Disco diamantato supersottile (1mm) a fascia turbo per gres porcellanato, ceramica delicata, marmo.  
 · Ultradünne Diamantscheibe (1 mm) mit Turbostrand für Feinsteinzeug, empfindliche Keramik und Marmor.  
 · Disco diamantado ultrafino (1 mm) de banda turbo para gres porcelánico, cerámica delicada y mármol.



**Art. STL76GF**

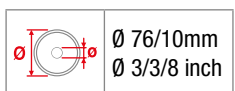

· Mola diamantata grana fine per taglio e levigatura di gres porcellanato, ceramica delicata, marmo.  
 · Feinkörnige Diamant-Schleifscheibe zum Schneiden und Schleifen von Feinsteinzeug, empfindlicher Keramik und Marmor.  
 · Disque diamanté ultra-fin (1 mm) à jante turbo pour le grès cérame, la céramique délicate et le marbre.



**Art. MIDIFLEXIMONT-GG**

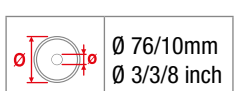

· Disco diamantato lamellare grana grossa per gres porcellanato, ceramica, granito, marmo e vetro.  
 · Lamellen-Diamantscheibe mit grober Körnung für Feinsteinzeug, Keramik, Granit, Marmor und Glas.  
 · Disque diamanté à lamelles à gros grain pour le grès cérame, la céramique, le granit, le marbre et le verre.



**Art. MIDIFLEXIMONT-GM**

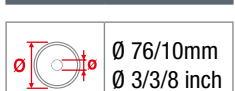

· Disco diamantato lamellare grana media per gres porcellanato, ceramica, granito, marmo e vetro.  
 · Lamellen-Diamantscheibe mit mittlerer Körnung für Feinsteinzeug, Keramik, Granit, Marmor und Glas.  
 · Disque diamanté à lamelles à moyen grain pour le grès cérame, la céramique, le granit, le marbre et le verre.



# TCS - TURBO THIN

**NEW**

Gres porcellanato/Ceramica dura  
Feinsteinzeug/Harte Keramikfliesen  
Grès vitrifié/Céramique compacte



**RED LINE**  
"PROFESSIONAL"

Velocità - Geschwindigkeit - Vitesse	Durata - Dauer - Durée	Finitura - Endbearbeitung - Finition
★★★★☆	★★★★☆	★★★★☆

7 mm



Mini disco, ultrasottile  
Mini-Scheibe, ultradünn  
Mini-disque, ultra-mince

Art.				
	mm	inch	mm*	mm
<b>NEW</b> TCS76	76	3	10	1,0
TCS85 *	85	3-3/8	22,2*	1,0

\* 5/8 inch: Riduzione a richiesta • Reduzierung auf Anfrage • Réduction sur demande

\* **X**LOCK: A richiesta • Auf Anfrage • Sur demande

IT	DE	FR	
Gres porcellanato	Feinsteinzeug	Grès vitrifié	★★★★☆
Lastre sottili in gres porcellanato	Feinsteinzeugplatten dünn	Dalles de grès cérame mince	★★★★☆
Gres porcellanato alto spessore	Dickes Feinsteinzeug	Grès cérame à haute épaisseur	★★★★☆
Piastrelle in granito e pietra naturale	Granitfliesen und Naturstein	Carreaux de granit et de la pierre naturelle	★★★★☆
Piastrelle delicate, piastrelle in marmo	Empfindliche Fliesen, Marmorfliesen	Céramique délicates, carreaux de marbre	★★★★☆



# TCS-R - TURBO THIN

Gres porcellanato/Ceramica dura  
Feinsteinzeug/Harte Keramikfliesen  
Grès vitrifié/Céramique compacte



Velocità - Geschwindigkeit - Vitesse	Durata - Dauer - Durée	Finitura - Endbearbeitung - Finition
★★★★☆	★★★★☆	★★★★☆

Art.	Ø		Ø		
	mm	inch	mm*	mm	
TCS100R	100	4	22,2/15,8	1,4	
TCS115R *	115	4,5	22,2	1,4	
TCS125R *	125	5	22,2	1,4	
Special for MOTO FLASH LINE TCS150MFL	150	6	30/22,2	1,4	
TCS250R	250	10	30/25,4	1,65	

8,5 mm

Special for MOTO FLASH LINE

\* 5/8 inch: Riduzione a richiesta • Reduzierung auf Anfrage • Réduction sur demande

\* XLOCK: A richiesta • Auf Anfrage • Sur demande

Rinforzato  
Verstärkte  
Renforcé



Art TCS150MFL

Ultrasottile  
Ultradünn  
Ultra-mince



Art TCS100R

IT	DE	FR	
Gres porcellanato	Feinsteinzeug	Grès vitrifié	★★★★☆
Lastre sottili in gres porcellanato	Feinsteinzeugplatten dünn	Dalles de grès cérame mince	★★★★☆
Gres porcellanato alto spessore	Dickes Feinsteinzeug	Grès cérame à haute épaisseur	★★★★☆
Piastrelle in granito e pietra naturale	Granitfliesen und Naturstein	Carreaux de granit et de la pierre naturelle	★★★★☆
Piastrelle delicate, piastrelle in marmo	Empfindliche Fliesen, Marmorfliesen	Céramique délicates, carreaux de marbre	★★★★☆

# CJ - CONTINUOUS RIM



Gres porcellanato/ Gres porcellanato spessorato/Ceramica/Granito  
 GranitFeinsteinzeug/dickes-Feinsteinzeug/Keramikfliesen/Granit  
 Grès vitrifié/ Grès cérame à haute épaisseur/Céramique/Granit



25 mm  
FULL DIAMOND

Velocità - Geschwindigkeit - Vitesse	Durata - Dauer - Durée	Finitura - Endbearbeitung - Finition
★★★★☆	★★★★★	★★★★☆

Art.				
	mm	inch	mm*	mm
CJ115	115	4,5	22,2	1,6
CJ125	125	5	22,2	1,6

\* 5/8 inch: Riduzione a richiesta • Reduzierung auf Anfrage • Réduction sur demande



Espositore  
Austellmodul  
Affichage

IT	DE	FR	
Gres porcellanato, klinker	Feinsteinzeug, Klinker	Grès vitrifié, klinker	★★★★★
Gres porcellanato alto spessore	Dickes Feinsteinzeug	Grès cérame à haute épaisseur	★★★★★
Piastrelle in monocottura, cotto	Einbrandfliese (Keramikfliesen), Cotto	Céramique monocuissons, brique	★★★★★
Piastrelle in granito e pietra naturale	Granitfliesen und Naturstein	Carreaux de granit et de la pierre naturelle	★★★★★
Lastre sottili in gres porcellanato	Feinsteinzeugplatten schlank	Dalles de grès cérame mince	★★★★☆

# TCHD - TURBO TECH



Gres porcellanato alta densità/Gres porcellanato spessorato/Granito/Pietra  
 Hochdichtes Feinsteinzeug / dickes Feinsteinzeug / Granit / Naturstein  
 Grès cérame haute densité / Grès cérame épais / Granit / Pierre



10 mm

Velocità - Geschwindigkeit - Vitesse	Durata - Dauer - Durée	Finitura - Endbearbeitung - Finition
★★★★☆	★★★★★	★★★★☆

Art.				
	mm	inch	mm*	mm
TCHD115	115	4,5	22,2	1,6
TCHD125	125	5	22,2	1,6

\* 5/8 inch: Riduzione a richiesta  
 Reduzierung auf Anfrage  
 Réduction sur demande



Espositore  
Austellmodul  
Affichage

IT	DE	FR	
Gres porcellanato alta densità	Hochdichtes Feinsteinzeug	Grès cérame haute densité	★★★★★
Gres porcellanato alto spessore	Dickes Feinsteinzeug	Grès cérame à haute épaisseur	★★★★★
Gres porcellanato, klinker, monocottura	Feinsteinzeug, Klinker, Einbrandfliese	Grès cérame, klinker, monocuissons	★★★★★
Piastrelle in granito e pietre naturali	Granitfliesen und Naturstein	Carreaux de granit et de la pierre naturelle	★★★★★
Lastre sottili in gres porcellanato	Feinsteinzeugplatten schlank	Dalles de grès cérame mince	★★★★☆

# CPJ - CONTINUOUS RIM

**NEW**

Gres porcellanato/Gres porcellanato spessorato  
 Ceramica dura/Granito/Marmo  
 Feinsteinzeug /Dickes Feinsteinzeug  
 Harte Keramikfliesen/Marmor/Granit  
 Grès vitrifié/Grès cérame à haute épaisseur  
 Céramique compacte/Marbre/Granit



SILVER LINE  
"TOP"

Velocità - Geschwindigkeit - Vitesse	Durata - Dauer - Durée	Finitura - Endbearbeitung - Finition
★★★★☆	★★★★☆	★★★★☆

Art.				
	mm	inch	mm*	mm
CPJ250	250	10	30/25,4	1,5

\* 5/8 inch: Riduzione a richiesta • Reduzierung auf Anfrage • Réduction sur demande

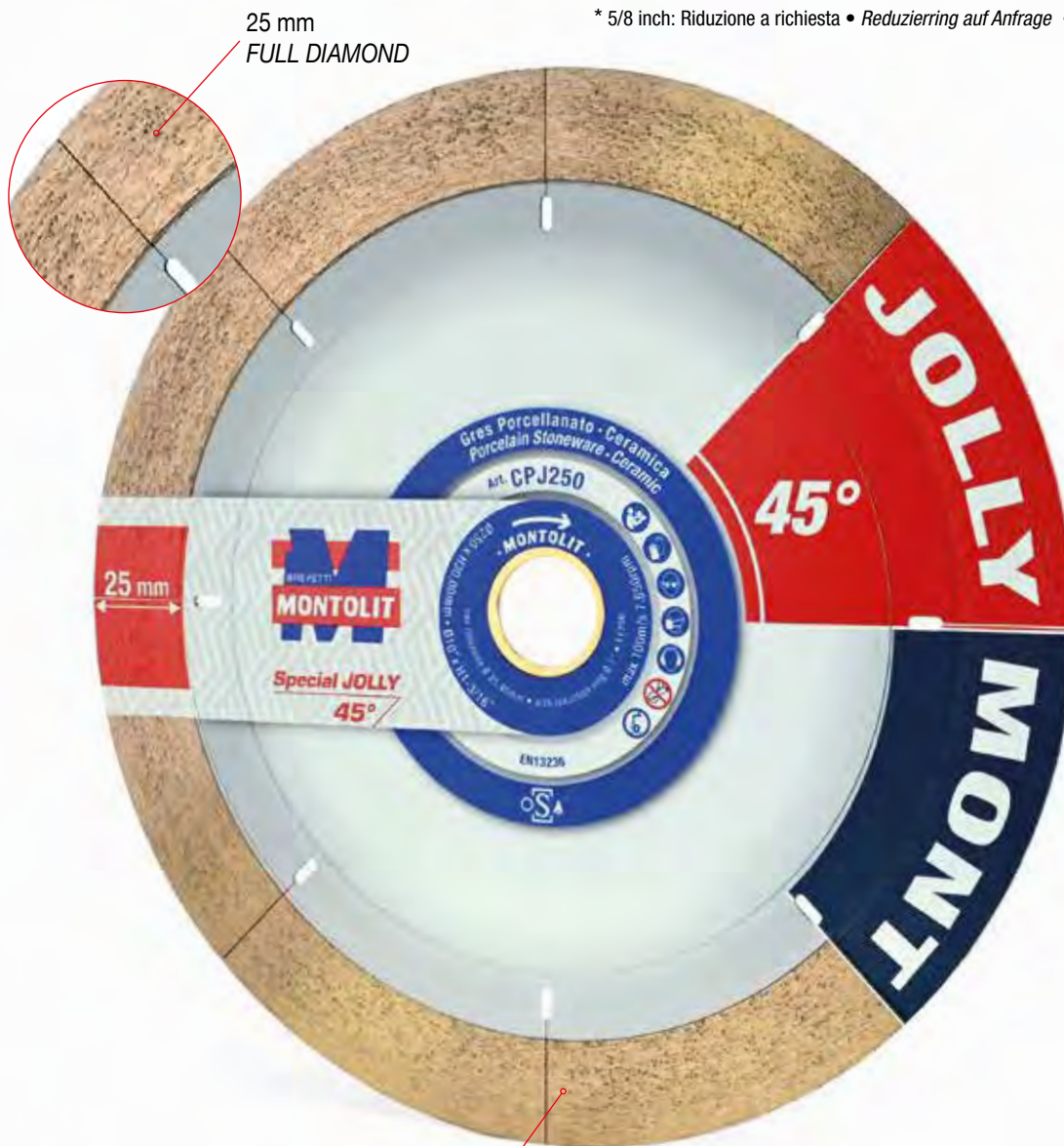

Massima finitura - Velocità ridotta - Non forzare  
 Maximales finish - Reduzierte Geschwindigkeit - Ohne Druck  
 Finition maximale - Vitesse réduite - Ne forcez pas

IT	DE	FR	
Gres porcellanato	Feinsteinzeug	Grès vitrifié	★★★★★
Gres porcellanato alto spessore	Dickes Feinsteinzeug	Grès cérame à haute épaisseur	★★★★★
Piastrelle in monocottura, cotto	Einbrandfliese (Keramikfliesen), Cotto	Céramique monocuissons, brique	★★★★★
Piastrelle in granito e pietra naturale	Granitfliesen und Naturstein	Carreaux de granit et de la pierre naturelle	★★★★★
Piastrelle in marmo	Marmorfliesen	Carreaux de marbre	★★★★☆

# CPV - CONTINUOUS RIM

Piastrelle in vetro  
 Glasfliesen  
 Carreaux en verre



Velocità - Geschwindigkeit - Vitesse	Durata - Dauer - Durée	Finitura - Endbearbeitung - Finition
☆☆☆☆	☆☆☆☆	☆☆☆☆

Art.				
	mm	inch	mm*	mm
CPV100	100	4	22,2	1,4
CPV180	180	7	30/25,4	1,6
CPV200	200	8	30/25,4	1,6
CPV250	250	10	30/25,4	1,9
CPV300	300	12	30/25,4	2,1

\* 5/8 inch: Riduzione a richiesta • Reduzierring auf Anfrage • Réduction sur demande

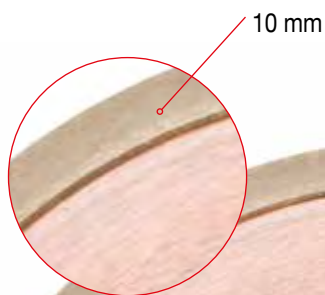

Massima finitura - Velocità ridotta - Non forzare  
 Maximales finish - Reduzierte Geschwindigkeit - Ohne Druck  
 Finition maximale - Vitesse réduite - Ne forcez pas



IT	DE	FR	
Piastrelle in vetro	Glasfliesen	Carreaux en verre	☆☆☆☆
Mosaico vetroso	Glasmosaik	Mosaïque en pâte de verre	☆☆☆☆
Mosaico in pietra naturale	Natursteinmosaik	Mosaïque en pierre naturelle	☆☆☆☆☆

# CPH - CONTINUOUS RIM

Ceramica/Gres porcellanato/Marmo/Granito  
 Keramikfliesen/Feinsteinzeug/Marmor/Granit  
 Céramique/Grès vitrifié/Marbre/Granit



**RED LINE**  
 "PROFESSIONAL"

Velocità - Geschwindigkeit - Vitesse	Durata - Dauer - Durée	Finitura - Endbearbeitung - Finition
★★★★☆	★★★★☆	★★★★☆

Art.						
	mm	inch	mm	mm		
CPH180	180	7	25,4/22,2	1,6		
CPH200	200	8	30/25,4	1,6		
CPH230	230	9	30/25,4	1,6		
CPH250	250	10	30/25,4	1,65		
CPH300	300	12	30/25,4	2,0		
CPH350	350	14	30/25,4	2,2		

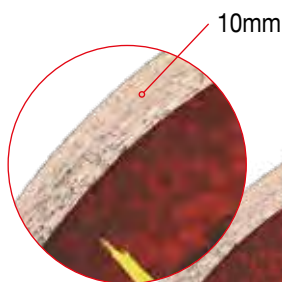

Massima velocità  
 Maximale Geschwindigkeit  
 Vitesse maximale

IT	DE	FR	
Gres porcellanato, klinker	Feinsteinzeug, Klinker	Grès vitrifié, klinker	★★★★★
Piastrelle in monocottura, cotto	Einbrandfliese (Keramikfliesen), Cotto	Céramique monocuissons, brique	★★★★★
Piastrelle in granito e pietra naturale	Granitfliesen und Naturstein	Carreaux de granit et de la pierre naturelle	★★★★☆
Piastrelle in marmo	Marmorfliesen	Carreaux de marbre	★★★★☆
Piastrelle in bicottura	Doppelbrand Keramikfliesen	Céramique bicuissin	★★★★☆

# CPF - CONTINUOUS RIM

Gres Porcellanato/Ceramica delicata/Vetro/Marmo/Granito  
 Feinsteinzeug/Empfindliche Keramiktiele/Glas/Marmor/Granit  
 Grès émaillé et délicat/Verre/Marbre/Granite



**RED LINE**  
 "PROFESSIONAL"

Velocità - Geschwindigkeit - Vitesse	Durata - Dauer - Durée	Finitura - Endbearbeitung - Finition
★★★★☆	★★★★☆	★★★★☆

Art.				
	mm	inch		
CPF180	180	7	25,4/22,2	2,0
CPF200	200	8	30/25,4	2,0
CPF230	230	9	30/25,4	2,0
CPF250	250	10	30/25,4	2,0
CPF300	300	12	30/25,4	2,2
CPF350	350	14	30/25,4	2,2



Massima finitura - Velocità ridotta - Non forzare  
 Maximales finish - Reduzierte Geschwindigkeit - Ohne Druck  
 Finition maximale - Vitesse réduite - Ne forcez pas

IT	DE	FR	
Piastrelle in vetro	Glasfliesen	Carreaux en verre	★★★★☆
Gres porcellanato	Feinsteinzeug	Grès vitrifié	★★★★☆
Piastrelle in monocottura e bicottura	Einmal- und Doppelbrand Keramikfliesen	Céramique monocuissons et bicusson	★★★★☆
Piastrelle in marmo	Marmorfliesen	Carreaux de marbre	★★★★☆
Piastrelle in granito e pietre naturali	Granitfliesen und Naturstein	Carreaux de granit et de la pierre naturelle	★★★★☆

# TEH - TURBO

Edilizia  
Bau Industrie  
Batiment



BLU LINE  
"UNIVERSAL"

Velocità - Geschwindigkeit - Vitesse	Durata - Dauer - Durée	Finitura - Endbearbeitung - Finition
★★★★☆	★★★★☆	★★★★☆

Art.	Ø		Ø		
	mm	inch	mm*	mm	
TEH115	115	4,5	22,2	2,2	
TEH125	125	5	22,2	2,2	
TEH230P	230	9	22,2	2,4	

\* 5/8 inch: Riduzione a richiesta • Reduzierring auf Anfrage • Réduction sur demande

IT	DE	FR	
Tegole, laterizio, mattoni, calcestruzzo	Dachziegel, Mauerziegel, Beton	Tuiles, brique, béton	★★★★★
Autobloccanti, arenaria, poroton®	Betonstein, Sandstein, Poroton®	Briques autobloquants, grès, poroton®	★★★★☆
Calcestruzzo leggermente armato, calcestruzzo abrasivo.	Leicht bewehrter Beton, abrasiver Beton.	Béton légèrement armé, béton abrasif.	★★★★☆
Granito, pietra, porfido	Granit, Stein, Porphyr	Granit, pierre, porphyre	★★★★☆
Marmo, ceramica, gres porcellanato.	Marmor, Keramik, Feinsteinzeug	Marbre, céramique, grès vitrifié	★★★☆☆

# TBH - TURBO PRO

Calcestruzzo/Granito/Gres porcellanato spessorato  
Beton/Granit/hoches/dickes-Feinsteinzeug  
Béton/Granit/Grès cérame à haute épaisseur



RED LINE  
"PROFESSIONAL"



Velocità - Geschwindigkeit - Vitesse	Durata - Dauer - Durée	Finitura - Endbearbeitung - Finition
★★★★★	★★★★★	★★★★★

Art.	Ø		Ø		
	mm	inch	mm*	mm	
TBH115 *	115	4,5	22,2	2,4	
TBH125 *	125	5	22,2	2,4	
TBH150	150	6	30/22,2	2,4	
TBH180	180	7	22,2	2,4	
TBH200	200	8	30/25,4	2,4	
TBH230P	230	9	22,2	2,4	
TBH250	250	10	30/25,4	2,8	
TBH300	300	12	30/25,4	2,8	
TBH350	350	14	30/25,4	3,3	

IT	DE	FR	
Tegole, laterizio, mattoni, calcestruzzo	Dachziegel, Mauerziegel, Beton	Tuiles, brique, béton	★★★★★
Granito, pietra, porfido, refrattario	Granit, Stein, Porphyr, Schamottestein	Granit, pierre, porphyre, réfractaire	★★★★★
Calcestruzzo leggermente armato, calcestruzzo abrasivo.	Leicht bewehrter Beton, abrasiver Beton.	Béton légèrement armé, béton abrasif.	★★★★☆
Autobloccanti, arenaria, poroton®	Betonstein, Sandstein, Poroton®	Briques autobloquants, grès, poroton®	★★★★☆
Marmo, ceramica, gres porcellanato.	Marmor, Keramik, Feinsteinzeug	Marbre, céramique, grès vitrifié	★★★☆☆

Speciale per gres porcellanato alto spessore  
Speziell für dickes Feinsteinzeug  
Spécial pour le grès cérame à haute épaisseur.

\* 5/8 inch: Riduzione a richiesta • Reduzierring auf Anfrage • Réduction sur demande

\* **XLOCK**: A richiesta • Auf Anfrage • Sur demande

# LEH - LASER

Edilizia  
Bau Industrie  
Batiment



Velocità - Geschwindigkeit - Vitesse	Durata - Dauer - Durée	Finitura - Endbearbeitung - Finition
★★★★☆	★★★★☆	★★★★☆

Art.	Ø		Ø	
	mm	inch	mm*	mm
LEH115	115	4,5	22,2	2,2
LEH125	125	5	22,2	2,2
LEH230P	230	9	22,2	2,4
LEH30018	300	12	30/25,4	2,8
LEH35021	350	14	30/25,4	3,2
LEH40024	400	16	30/25,4	3,4
LEH45026	450	18	30/25,4	3,6
LEH50029	500	20	30/25,4	3,6
LEH55032	550	22	30/25,4	4,0
LEH60035	600	24	60/50/25,4	4,0
LEH65037	650	26	60/50/25,4	4,0
LEH72040	720	29	60/50/25,4	4,0
LEH75042	750	30	60/50/25,4	4,0

\* 5/8 inch: Riduzione a richiesta • Reduzierring auf Anfrage • Réduction sur demande

# LBH - LASER PRO

Calcestruzzo/Granito/Porfido/Pietre dure  
Beton/Granit/Porphyr/Harter Stein  
Béton/Granit/Porphyre/Pierre dure

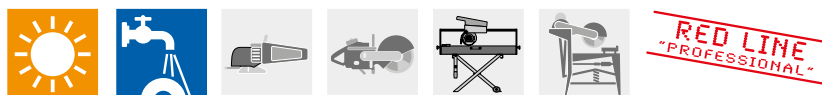

Velocità - Geschwindigkeit - Vitesse	Durata - Dauer - Durée	Finitura - Endbearbeitung - Finition
★★★★★	★★★★★	★★★★☆

Art.	Ø		Ø	
	mm	inch	mm*	mm
LBH115	115	4,5	22,2	2,0
LBH125	125	5	22,2	2,2
LBH150	150	6	22,2	2,4
LBH160	160	6-5/16	22,2	2,4
LBH180	180	7	22,2	2,4
LBH190	190	7,5	22,2	2,4
LBH200	200	8	30/25,4	2,4
LBH230P	230	9	22,2	2,4
LBH250	250	10	30/25,4	2,4
LBH30021	300	12	30/25,4	2,8
LBH35025	350	14	30/25,4	3,2
LBH40028	400	16	30/25,4	3,2
LBH45032	450	18	30/25,4	3,4

\* 5/8 inch: Riduzione a richiesta • Reduzierring auf Anfrage • Réduction sur demande

# LIH- LASER

Calcestruzzo fortemente armato/Granito/Porfido/Pietre dure/Ferro  
Stahlbeton/Granit/Porphyr/Harter Stein/Eisen  
Béton armé/Granit/Porphyre/Pierre dure/Fer



SILVER LINE  
"TOP"

10mm

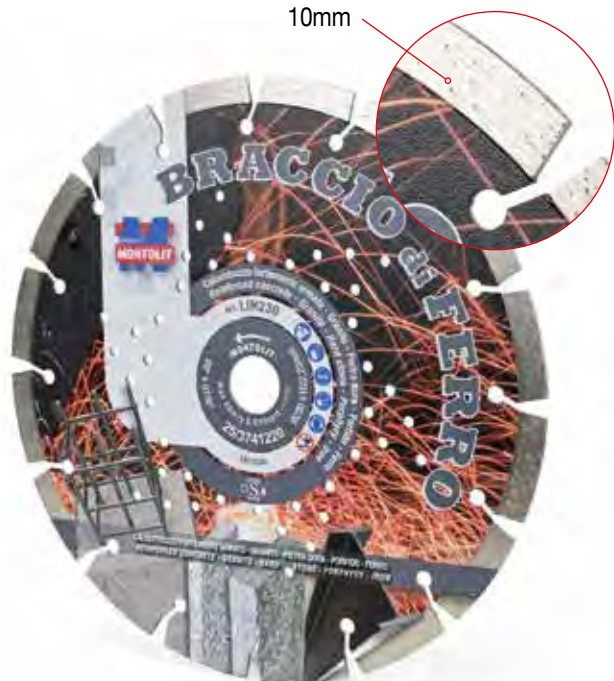

Velocità - Geschwindigkeit - Vitesse	Durata - Dauer - Durée	Finitura - Endbearbeitung - Finition
★★★★★	★★★★★	★★★☆☆

Art.				
LIH230	mm	inch	mm*	mm
	230	9	22,2	2,4

\* 5/8 inch: Riduzione a richiesta • Reduzierring auf Anfrage • Réduction sur demande

IT	DE	FR	
Calcestruzzo armato, calcestruzzo compatto	Stahlbeton, Beton-kompakt	Béton armé, béton compact	★★★★★
Calcestruzzo molto armato, ferro d'armatura	Viele Stahlbeton, Stahlbewehrung	Beaucoup béton armé, renforcement fer	★★★★★
Autobloccanti, arenaria, poroton®, refrattario	Betonstein, Sandstein, Poroton®, Schamottestein	Briques autobloquants, grès, poroton®, réfractaire	★★★★★
Granito, pietra, porfido	Granit, Stein, Porphyr	Granit, pierre, porphyre	★★★★★
Tegole, laterizio, mattoni	Dachziegel, Mauerziegel	Tuiles, brique	★★★★☆

# SR - SEGMENTS

Refrattario/Materiali abrasivi/Granito/Porfido  
Schamottestein/Schleifmittel/Granit/Porphyr  
Réfractaire/Matériaux abrasifs/Granit/Porphyre



SILVER LINE  
"TOP"

10mm



Velocità - Geschwindigkeit - Vitesse	Durata - Dauer - Durée	Finitura - Endbearbeitung - Finition
★★★★☆	★★★★★	★★★★☆

Art.					
	mm	inch	mm	mm	
SR30021	300	12	30/25,4	3,0	
SR35025	350	14	30/25,4	3,2	
SR40028	400	16	30/25,4	3,5	
SR45032	450	18	30/25,4	4,0	
SR50030	500	20	30/25,4	4,5	
SR55032 *	550	22	30/25,4	5,0	
SR60036	600	24	30/25,4	5,0	
SR65038 *	650	26	30/25,4	5,0	

\* A richiesta • Auf Anfrage • Sur demande

IT	DE	FR	
Tegole in cotto, laterizio, mattoni	Terrakotta-Dachziegel, Mauerziegel	Tuiles en brique, brique	★★★★★
Granito, pietra naturale	Granit, Naturstein	Granit, pierre naturelle	★★★★★
Autobloccanti, arenaria, poroton®	Betonstein, Sandstein, Poroton®	Briques autobloquants, grès, poroton®	★★★★★
Tegole in cemento, mattoni abrasivi	Beton-Dachpfannen, Schleif Ziegel	Tuiles en béton, briques abrasives	★★★★☆
Refrattario	Schamottestein.	Réfractaire	★★★★☆

# SSD - MONDRILLO

Gres/Marmo/Granito/Calcestruzzo/Ghisa/Metallo/Fibra di vetro/Plastica  
Steinzeug/Marmor/Granit/Beton/Gusseisen/Metall/Fiberglas/Kunststoff  
Grès/Marbre/Granit/Béton/Fonte/Métal/Fibre de verre/Plastique



SILVER LINE  
"TOP"



**MULTI  
POURPOSE**

Velocità - Geschwindigkeit - Vitesse	Durata - Dauer - Durée	Finitura - Endbearbeitung - Finition
★★★★★	★★★☆☆	★★★★★

Art.	Ø		Ø
	mm	inch	mm*
SSD115	115	4,5	22,2
SSD125	125	5	22,2
SSD230	230	9	22,2
SSD300	300	12	30/25,4
SSD350	350	14	30/25,4

\* 5/8 inch: Riduzione a richiesta • Reduzierring auf Anfrage • Réduction sur demande



IT	DE	FR	
Granito, marmo, pietra naturale	Granit, Marmor, Naturstein	Granit, marbre, pierre naturelle	★★★★★
Calcestruzzo, materiali edili.	Beton, Baustoffe	Béton, matériaux de construction	★★★★★
Barre in acciaio, tubi in ghisa.	Stahlstangen, Gusseisenrohre	Barres d'acier, tuyaux en fonte	★★★★☆
Plastica, PVC, vetroresina, legno.	Kunststoff, PVC, Glasfaser, Holz	Plastique, PVC, fibre de verre, bois	★★★★☆
Gres porcellanato, ceramica.	Feinsteinzeug, Keramik	Grès cérame, céramique	★★★★☆

# ED - ELECTROPLATED

Marmo/Fibre di vetro/Vetroresina  
Marmor/Fiberglas  
Marbre/Fibres de verre



SILVER LINE  
"TOP"



Velocità - Geschwindigkeit - Vitesse	Durata - Dauer - Durée	Finitura - Endbearbeitung - Finition
★★★★★	★★★☆☆	★★★★★

Art.	Ø		Ø
	mm	inch	mm*
ED115	115	4,5	22,2
ED125	125	5	22,2
ED180	180	7	22,2
ED200	200	8	22,2
ED230P	230	9	22,2
ED250	250	10	30/25,4
ED300	300	12	30/25,4
ED350	350	14	30/25,4

\* 5/8 inch: Riduzione a richiesta • Reduzierring auf Anfrage • Réduction sur demande

Marmo bianco e colorato.	Weißer und farbiger Marmor	Blanc et marbre de couleur	★★★★★
Vetroresina, fibre di vetro.	Glasfasern	Fibre de verre	★★★★☆
Plastica, PVC.	Kunststoff, PVC	Plastique, PVC	★★★★☆

# CZ - CONTINUOUS RIM

Gres porcellanato/Ceramica  
Feinsteinzeug/Keramikfliesen  
Grès vitrifié/Céramique



**GREEN LINE**  
"BASIC"

Velocità - Geschwindigkeit - Vitesse	Durata - Dauer - Durée	Finitura - Endbearbeitung - Finition
★★★★☆	★★★☆☆	★★★★☆

Art.				
	mm	inch	mm*	mm
CZ100	100	4	22,2/15,8	1,4
CZ115	115	4,5	22,2	1,4
CZ125	125	5	22,2	1,4
CZ180	180	7	22,2	1,6

\* 5/8 inch: Riduzione a richiesta • Reduzierring auf Anfrage • Réduction sur demande

# TCS-E - CONTINUOUS RIM

Ceramica/Gres porcellanato  
Keramikfliesen/Feinsteinzeug  
Céramique/Grès vitrifié



**GREEN LINE**  
"BASIC"

Velocità - Geschwindigkeit - Vitesse	Durata - Dauer - Durée	Finitura - Endbearbeitung - Finition
★★★★☆	★★★☆☆	★★★★☆

Art.				
	mm	inch	mm*	mm
TCS100E	100	4	22,2/15,8	1,4
TCS115E	115	4,5	22,2	1,4
TCS125E	125	5	22,2	1,4

\* 5/8 inch: Riduzione a richiesta • Reduzierring auf Anfrage • Réduction sur demande

# TZ - TURBO

Edilizia  
Bau Industrie  
Batiment



**GREEN LINE**  
"BASIC"

Velocità - Geschwindigkeit - Vitesse	Durata - Dauer - Durée	Finitura - Endbearbeitung - Finition
★★★★☆	★★★☆☆	★★★★☆

Art.				
	mm	inch	mm*	mm
TZ115	115	4,5	22,2	2,0
TZ230P	230	9	22,2	2,6

\* 5/8 inch: Riduzione a richiesta • Reduzierring auf Anfrage • Réduction sur demande

Foratura  
*Bohren*  
*Perçage*



# FTJ - KILLER GRES · SINTERED DRY DRILLING

Gres porcellanato/Ceramica/Monocottura/Granito  
 Feinsteinzeug/Steinzeug (Keramikfliesen)/Granit  
 Grés vitrifié/Céramique/Monocuisson/Granit

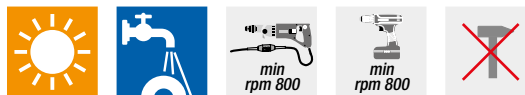

Velocità - Geschwindigkeit - Vitesse	Durata - Dauer - Durée	Finitura - Endbearbeitung - Finition
★★★★☆	★★★★★	★★★★☆



Lunga durata  
 Langes Leben  
 Longue durée



Art.	Ø		max mm	
	mm	inch	mm	max mm
FTJ05	5	3/16	10	30
FTJ06	6	1/4	10	30
FTJ08	8	5/16	10	30
FTJ10	10	3/8	10	30
FTJ12	12	1/2	10	30

Art. FTJVA-N | Box + FTJ 05/06/08/10/12



IT	DE	FR	
Gres porcellanato	Feinsteinzeug	Grès vitrifié	★★★★★
Piastrelle di monocottura, granito	Einmalbrand (Keramikfliesen), Granite	Céramique monocuissons, granit	★★★★★
Granito, pietre naturali	Granite, Naturstein	Granit, pierre naturelle	★★★★☆
Piastrelle di bicottura e vetrose	Doppelbrand Keramikfliesen und glasierte	Céramique bicuisson et vitrifiés	★★★★☆
Marmo e piastrelle in marmo	Marmor und Marmorfliesen	Marbre et carreaux de marbre	★★★★☆



Art. FTJVA-N



pg. 94 → Liquido refrigerante  
 Kühlpaste  
 Fluide réfrigérant

# FAJ - MONDRILLO · DRY DRILLING

Gres porcellanato/Ceramica/Monocottura/Granito/Marmo/Vetro  
 Feinsteinzeug/Steinzeug (Keramikfliesen)/Marmor/Granit/Glas  
 Grés vitrifié/Céramique/Monocuisson/Granit/Marbre/Verre

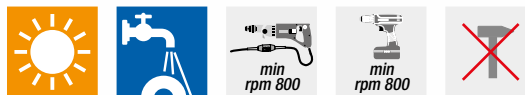

Velocità - Geschwindigkeit - Vitesse	Durata - Dauer - Durée	Finitura - Endbearbeitung - Finition
★★★★	★★☆☆	★★★★

4<sup>th</sup> generation gold diamond technology

**+ SPEED  
+ LIFE**

Gold spiral - new technology

Art.				
	mm	inch	mm	max mm
FAJ04	4	5/32	10	40
FAJ05	5	3/16	10	40
FAJ06	6	1/4	10	40
FAJ08	8	5/16	10	40
FAJ10	10	3/8	10	40
FAJ12	12	1/2	10	40
FAJVA-N	Box + FAJ 05/06/08/10/12			
FAJ6VA	Box + 5 art.FAJ06			
FAJ8VA	Box + 5 art.FAJ08			



IT	DE	FR	
Gres porcellanato	Feinsteinzeug	Grès vitrifié	★★★★
Piastrelle in monocottura, granito	Einmalbrand (Keramikfliesen), Granite	Céramique monocuissons, granit	★★★★
Marmo e piastrelle in marmo	Marmor und Marmorfliesen	Marbre et carreaux de marbre	★★★★
Piastrelle in bicottura e vetrose, vetro	Doppelbrand Keramikfliesen und glasierte, Glas	Céramique bicuisson et vitrifiés, verre	★★★★☆
Piastrelle in granito e pietre naturali	Granitfliesen und Naturstein	Carreaux de granit et de la pierre naturelle	★★★★☆



Art. FAJVA-N



pg. 107 → Espositore  
Austellmodul  
Affichage

pg. 94 → Liquido refrigerante  
Kühlpaste  
Fluide réfrigérant



# FSBH - MONDRILLO · DRY DRILLING

**NEW**

Piastrelle in ceramica e pietra naturale  
 Keramikfliesen und Naturstein  
 Carreaux en céramique et pierre naturelle



Velocità - Geschwindigkeit - Vitesse	Durata - Dauer - Durée	Finitura - Endbearbeitung - Finition
★★★★★	★★★☆☆	★★★★☆



12mm



Art.

Art.	Ø		max mm
	mm	inch	
FSBH 06	6	1/4	M14 * 35
FSBH 08	8	5/16	M14 * 35
FSBH 10	10	3/8	M14 * 35
FSBH 12	12	1/2	M14 * 35
FSBH 14	14	9/16	M14 * 35
FSBH 16	16	5/8	M14 * 35
FSBH 18	18	11/16	M14 * 35
FSBH 20	20	3/4	M14 * 35
FSBH 25	25	1	M14 * 35
FSBH 27	27	1-1/16	M14 * 35
FSBH 30	30	1-3/16	M14 * 35
FSBH 35	35	1-3/8	M14 * 35
FSBH 40	40	1-1/2	M14 * 35
FSBH 45	45	1-3/4	M14 * 35
FSBH 50	50	2	M14 * 35
FSBH 55	55	2-3/16	M14 * 35
FSBH 60	60	2-3/8	M14 * 35
FSBH 65	65	2-1/2	M14 * 35
FSBH 68	68	2-11/16	M14 * 35
FSBH 70	70	2-3/4	M14 * 35
FSBH 75	75	3	M14 * 35
FSBH 90	90	3-9/16	M14 * 35
FSBH100	100	4	M14 * 35
FSBH120	120	4-3/4	M14 * 35



Art. FSBHKIT-IT

FSBHKIT-IT	Box + FSBH08 + FSBH20 + FSBH27 + FSBH35 + FSHB50
FSBHKIT-AT	Box + FSBH20 + FSBH27 + FSBH35 + FSHB50 + FSBH65

\* 5/8 inch: A richiesta • Auf Anfrage • Sur demande

IT	DE	FR	
Gres porcellanato	Feinsteinzeug	Grès vitrifié	★★★★★
Piastrelle in granito e pietra naturali	Granitfliesen und Naturstein	Carreaux de granit et de la pierre naturelle	★★★★★
Piastrelle in monocottura, granito	Einmalbrand (Keramikfliesen), Granite	Céramique monocuissons, granit	★★★★★
Marmo e piastrelle in marmo	Marmor und Marmorfliesen	Marbre et carreaux de marbre	★★★★★
Piastrelle in bicottura e vetrose	Doppelbrand Keramikfliesen und glasierte	Céramique bicuisson et vitrifiés	★★★★☆



pg. 94

Liquido refrigerante  
 Kühlpaste  
 Fluide réfrigérant



# FS-TI - MONDRILLO <sup>TITANIUM</sup> GOLD - DRY DRILLING



Gres Porcellanato/Ceramica dura/Granito/Marmo  
Feinsteinzeug/Harte Keramikfliesen/Marmor/Granit  
Grés vitrifié/Cèramique compacte/Granit/Marbre



Velocità - Geschwindigkeit - Vitesse	Durata - Dauer - Durée	Finitura - Endbearbeitung - Finition
★★★★★	★★★★☆	★★★★☆



Art.	Ø		M14 *	max mm
	mm	inch		
FS-TI 6	6	1/4	M14 *	35
FS-TI 8	8	5/16	M14 *	35
FS-TI 10	10	3/8	M14 *	35
FS-TI 12	12	1/2	M14 *	35
FS-TI 14	14	9/16	M14 *	35
FS-TI 16	16	5/8	M14 *	35
FS-TI 18	18	11/16	M14 *	35
FS-TI 20	20	3/4	M14 *	35
FS-TI 25	25	1	M14 *	35
FS-TI 27	27	1-1/16	M14 *	35
FS-TI 30	30	1-3/16	M14 *	35
FS-TI 35	35	1-3/8	M14 *	35
FS-TI 40	40	1-1/2	M14 *	35
FS-TI 45	45	1-3/4	M14 *	35
FS-TI 50	50	2	M14 *	35
FS-TI 55	55	2-3/16	M14 *	35
FS-TI 60	60	2-3/8	M14 *	35
FS-TI 65	65	2-1/2	M14 *	35
FS-TI 68	68	2-11/16	M14 *	35
FS-TI 70	70	2-3/4	M14 *	35
FS-TI 75	75	3	M14 *	35
FS-TI100	100	4	M14 *	35
FS-TI120	120	4-3/4	M14 *	35

FS-TI\_KIT-IT | Box + FS-TI8 + FS-TI20 + FS-TI27 + FS-TI35 + FS-TI50

\* 5/8 inch: A richiesta • Auf Anfrage • Sur demande



Art. FS-TI\_KIT-IT

## Art. AUFS



Raccordo per trapano - M14  
Adapter für Bohrmaschine - M14  
Adaptateur pour perceuse - M14

IT	DE	FR	
Gres porcellanato	Feinsteinzeug	Grès vitrifié	★★★★★
Piastrelle in granito e pietre naturali	Granitfliesen und Naturstein	Carreaux de granit et de la pierre naturelle	★★★★★
Piastrelle in monocottura, granito	Einmalbrand (Keramikfliesen), Granite	Céramique monocuissions, granit	★★★★★
Marmo e piastrelle in marmo	Marmor und Marmorfliesen	Marbre et carreaux de marbre	★★★★★
Piastrelle in bicottura e vetrose	Doppelbrand Keramikfliesen und glasierte	Céramique bicuission et vitrifiés	★★★★☆

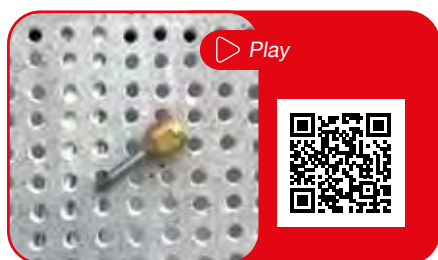

pg. 94 → Liquido refrigerante  
Kühlpaste  
Fluide réfrigérant

# FT - KILLER GRES · SINTERED DRY DRILLING

Gres porcellanato/Ceramica dura/Granito  
Feinsteinzeug/Harte Keramikfliesen/Granit  
Grés vitrifié/Céramique compacte/Granit



Velocità - Geschwindigkeit - Vitesse	Durata - Dauer - Durée	Finitura - Endbearbeitung - Finition
★★★★☆	★★★★★	★★★★☆



8mm

Art.	Ø		MAX	
	mm	inch	mm	max mm
FT 6	6	1/4	10	45
FT 8	8	5/16	10	45
FT 10	10	3/8	10	45
FT 15	15	5/8	10	45
FT 20	20	3/4	10	45
FT 27	27	1-1/16	10	45
FT 35	35	1-3/8	10	45
FT 40	40	1-1/2	10	45
FT 50	50	2	10	45
FT 60	60	2-3/8	10	45
FT 65	65	2-1/2	10	45
FT 75	75	3	10	45
FT100	100	4	10	45
FT120	120	4-3/4	10	45

# FT-SB - KILLER GRES · SINTERED DRY DRILLING



Gres porcellanato alto spessore/Ceramica dura/Granito  
Feinsteinzeug-Hoch Dicke/Harte Keramikfliesen/Granit  
Grés vitrifié épaisseur haut/Céramique compacte/Granit

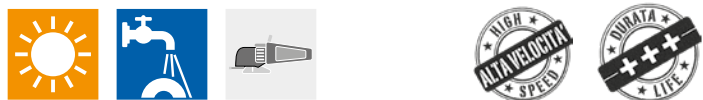

Velocità - Geschwindigkeit - Vitesse	Durata - Dauer - Durée	Finitura - Endbearbeitung - Finition
★★★★★	★★★★☆	★★★★☆



6mm

Art.	Ø		MAX		MAX rpm
	mm	inch	mm	max mm	
FT-SB 6	6	1/4	M14	40	6.000
FT-SB 8	8	5/16	M14	40	6.000
FT-SB10	10	3/8	M14	40	6.000
FT-SB12	12	1/2	M14	40	6.000
FT-SB15	15	5/8	M14	50	12.000
FT-SB20	20	3/4	M14*	50	12.000
FT-SB25	25	1	M14*	50	12.000
FT-SB27	27	1-1/16	M14*	50	12.000
FT-SB30	30	1-3/16	M14*	50	12.000
FT-SB35	35	1-3/8	M14*	50	12.000
FT-SB40	40	1-1/2	M14*	50	12.000
FT-SB43	43	1-11/16	M14*	50	12.000
FT-SB50	50	2	M14*	50	12.000
FT-SB55	55	2-3/16	M14*	50	12.000
FT-SB60	60	2-3/8	M14*	50	12.000
FT-SB65	65	2-1/2	M14*	50	12.000
FT-SB68	68	2-11/16	M14*	50	12.000
FT-SB70	70	2-3/4	M14*	50	12.000
FT-SB100	100	4	M14*	50	4.000
FT-SB120	120	4-3/4	M14*	50	4.000

\* 5/8 inch: A richiesta • Auf Anfrage • Sur demande



Speciale per gres porcellanato alto spessore  
Speziell für dickes Feinsteinzeug  
Spécial pour le grés cérame à haute épaisseur.

# FT-S - KILLER GRES · SINTERED DRY DRILLING

**NEW**

Gres porcellanato alto spessore/Ceramica dura/Granito  
 Feinsteinzeug-Hoch Dicke/Harte Keramikfliesen/Granit  
 Grés vitrifié épaisseur haut/Céramique compacte/Granit



Velocità - Geschwindigkeit - Vitesse	Durata - Dauer - Durée	Finitura - Endbearbeitung - Finition
★★★★	★★★★	★★★☆☆

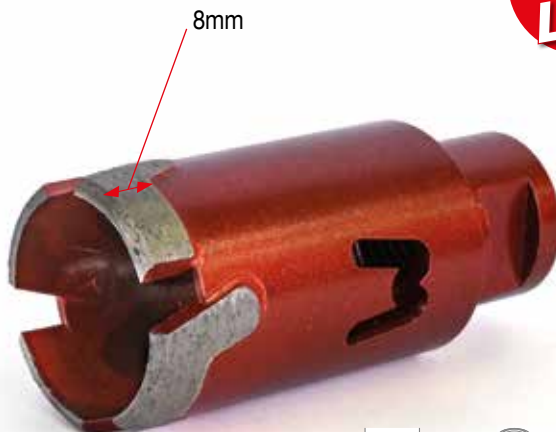

**TOP LIFE**



Speciale per gres porcellanato alto spessore  
 Speziell für dickes Feinsteinzeug  
 Spécial pour le grès cérame à haute épaisseur.



Art.	Ø		mm	max mm	MAX rpm
	mm	inch			
FT-S 6	6	1/4	M14	40	6.000
FT-S 8	8	5/16	M14	40	6.000
FT-S10	10	3/8	M14*	40	6.000
FT-S12	12	1/2	M14*	40	6.000
FT-S15	15	5/8	M14*	50	12.000
FT-S20	20	3/4	M14*	50	12.000
FT-S25	25	1	M14*	50	12.000
FT-S27	27	1-1/16	M14*	50	12.000
FT-S30	30	1-3/16	M14*	50	12.000
FT-S35	35	1-3/8	M14*	50	12.000
FT-S40	40	1-1/2	M14*	50	12.000
FT-S43	43	1-11/16	M14*	50	12.000
FT-S50	50	2	M14*	50	12.000
FT-S55	55	2-3/16	M14*	50	12.000
FT-S60	60	2-3/8	M14*	50	12.000
FT-S65	65	2-1/2	M14*	50	12.000
FT-S68	68	2-11/16	M14*	50	12.000
FT-S70	70	2-3/4	M14*	50	12.000
FT-S100	100	4	M14*	50	4.000
FT-S120	120	4-3/4	M14*	50	4.000

FTSKIT-IT | Box + FT-S20 + FT-S35 + FT-S50

\* 5/8 inch: A richiesta • Auf Anfrage • Sur demande

IT	DE	FR	
Gres porcellanato alto spessore	Feinsteinzeug-Hoch Dicke	Grés vitrifié épaisseur haut	★★★★★
Gres porcellanato	Feinsteinzeug	Grès vitrifié	★★★★★
Piastrelle in granito e pietre naturali	Granitfliesen und Naturstein	Carreaux de granit et de la pierre naturelle	★★★★★
Piastrelle in monocottura	Einmalbrand (Keramikfliesen)	Céramique monocuissons	★★★☆☆
Marmo e piastrelle in marmo	Marmor und Marmorfliesen	Marbre et carreaux de marbre	★★★☆☆



pg. 94

Liquido refrigerante  
 → Kühlpaste  
 Fluide réfrigérant

pg. 107

Espositore  
 → Austellmodul  
 Affichage

# MU - SINTERED WET DRILLING

Gres porcellanato/Ceramica/Monocottura/Granito/Marmo  
Feinsteinzeug/Steinzeug (Keramikfliesen)/Granit/Marmor  
Grès vitrifié/Cèramique/Monocuisson/Granit/Marbre



Velocità - Geschwindigkeit - Vitesse	Durata - Dauer - Durée	Finitura - Endbearbeitung - Finition
★★★★☆	★★★★★	★★★★★

Art.				
	mm	inch	mm	max mm
MU 5	5	3/16	10	45
MU 6	6	1/4	10	45
MU 8	8	5/16	10	45
MU10	10	3/8	10	45
MU12	12	1/2	10	45
MU14	14	9/16	10	45

IT	DE	FR	
Piastrelle in monocottura, granito	Einbrandfliese (Keramikfliesen), Granite	Céramique monocuissons, granit	★★★★★
Piastrelle in granito e pietre naturali	Granitfliesen und Naturstein	Carreaux de granit et de la pierre naturelle	★★★★★
Piastrelle in bicottura e vetrose	Doppelbrand Keramikfliesen und glasierte	Céramique bicuisson et vitrifiés	★★★★★
Gres porcellanato	Feinsteinzeug	Grès vitrifié	★★★★★
Marmo e piastrelle in marmo	Marmor und Marmorfliesen	Marbre et carreaux de marbre	★★★★☆

# FAV - SINTERED WET DRILLING

Piastrelle in vetro/Ceramica delicata  
Glasfliesen/Empfindliche Keramikteile  
Carreaux en verre/Cèramique delicat



Velocità - Geschwindigkeit - Vitesse	Durata - Dauer - Durée	Finitura - Endbearbeitung - Finition
★★★★☆	★★★★★	★★★★★

Art.				
	mm	inch	mm	max mm
FAV20	20	3/4	M16	30
FAV28	28	1-1/16	M16	30
FAV35	35	1-3/8	M16	30
FAV51	51	2	M16	30
FAV65	65	2-1/2	M16	30

IT	DE	FR	
Piastrelle in vetro	Glasfliesen	Carreaux en verre	★★★★★
Piastrelle in bicottura e vetrose	Doppelbrand Keramikfliesen und glasierte	Céramique bicuisson et vitrifiés	★★★★★
Gres porcellanato	Feinsteinzeug	Grès vitrifié	★★★★☆
Marmo e piastrelle in marmo	Marmor und Marmorfliesen	Marbre et carreaux de marbre	★★★★☆



# FA - SINTERED WET DRILLING

Gres porcellanato/Ceramica/Monocottura/Granito/Marmo  
 Feinsteinzeug/Steinzeug (Keramikfliesen)/Granit/Marmor  
 Grès vitrifié/Céramique/Monocuisson/Granit/Marbre



Velocità - Geschwindigkeit - Vitesse	Durata - Dauer - Durée	Finitura - Endbearbeitung - Finition
★★★★☆	★★★★☆	★★★★☆



Art.	Ø		M	max mm
	mm	inch		
FA 20	20	3/4	M16	45
FA 27	27	1-1/16	M16	45
FA 30	30	1-3/16	M16	45
FA 32	32	1-1/4	M16	45
FA 35	35	1-3/8	M16	45
FA 40	40	1-1/2	M16	45
FA 45	45	1-3/4	M16	45
FA 50	50	2	M16	45
FA 55	55	2-3/16	M16	45
FA 60	60	2-3/8	M16	45
FA 65	65	2-1/2	M16	45
FA 70	70	2-3/4	M16	45
FA 75	75	3	M16	45
FA100	100	4	M16	45
FA120	120	4-3/4	M16	45

VAF01	BOX + 88 + FA20 + FA27 + FA30 + FA35 + FA40 + FA45 + FA50 + FA65 + FA75 + FA100 + FA120
VAF01	BOX

IT	DE	FR	
Gres porcellanato	Feinsteinzeug	Grès vitrifié	★★★★☆
Piastrelle in monocottura, granito	Einbrandfliese (Keramikfliesen), Granite	Céramique monocuissons, granit	★★★★☆
Marmo e piastrelle in marmo	Marmor und Marmorfliesen	Marbre et carreaux de marbre	★★★★☆
Piastrelle in bicottura e vetrose	Doppelbrand Keramikfliesen und glasierte	Céramique bicuisson et vitrifiés	★★★★☆
Granito, pietre naturali	Granite, Naturstein	Granit, pierre naturelle	★★★★☆

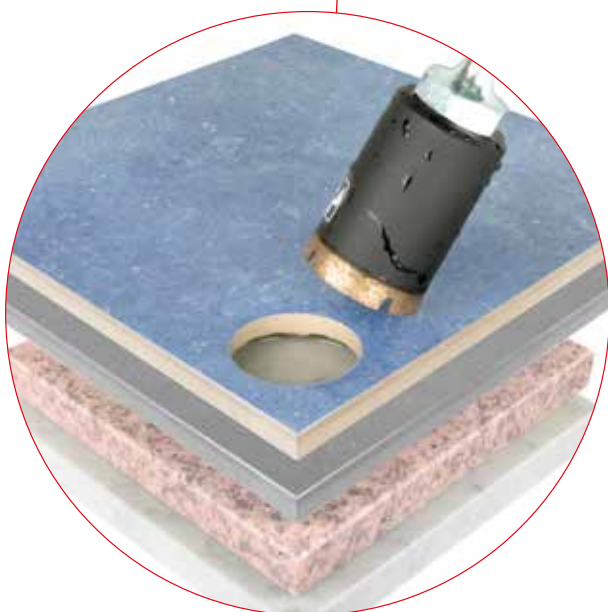

Art. VAF01

Art. AUFA		Art. 88		Art. VTKIT		pg. 96 →
-----------	--	---------	--	------------	--	----------

# MONDRILLO PERFORMER

Art. M-Performer

IT Fluido refrigerante per prestazioni ottimali delle punte diamantate.  
 DE Kühlflüssigkeit für optimale Leistung von Diamantbohrkronen.  
 FR Fluide de refroidissement pour une performance optimale des forets diamantés.

50 ml



# STONE SUPERCUT

IT Ravnivatori per utensili diamantati.  
 DE Schärffstein für Diamantwerkzeuge.  
 FR Pierre pour reaffuter les outils diamants.



Art.

395-2U	Special Multipurpose (206 x 73 x 30 mm)
395BJ	Junior (80 x 50 x 20 mm)

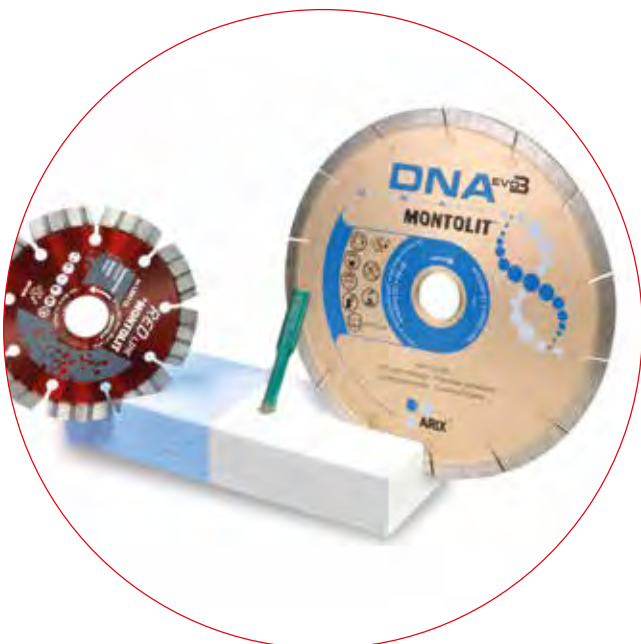

Art. 395BJ



Art. 395-2U

# SAFE DIAMOND BOX

Art. SDB

IT Custodia protettiva per utensili diamantati.  
DE Transportbox zur sicheren Aufbewahrung von Diamantwerkzeugen.  
FR Malette de protection pour outils diamantés.

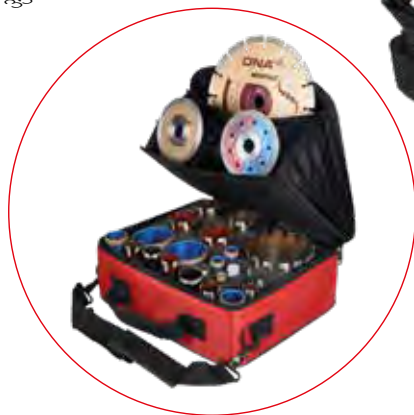

# SAFE DIAMOND BOX JUNIOR

Art. SDB JUNIOR

IT Custodia protettiva per utensili diamantati.  
DE Transportbox zur sicheren Aufbewahrung von Diamantwerkzeugen.  
FR Malette de protection pour outils diamantés.



## ACCESSORI PER LA FORATURA AD ACQUA

### AUSRÜSTUNG FÜR "NABBOHRUNG" - OUTILLAGE POUR LE PERÇAGE A EAU

<b>Art. PS92</b>	Raccordo portapunta per MU (x artt. 915/916/CVG12) Bohrhalter mit Madenschraube für MU (x artt. 915/916/CVG12) Raccord porte-foret pour MU (x artt. 915/916/CVG12)	
<b>Art. AUFA</b>	Raccordo per trapano - M16 (x artt. FA/FAV) Adapter für Bohrmaschine - M16 (x artt. FA/FAV) Adaptateur pour perceuse - M16 (x artt. FA/FAV)	
<b>Art. 88</b>	Mandrino a punta centrale retraente - M16 (x artt. FA/FAV) Spindel mit gefedertem Zentrierbohrer - M16 (x artt. FA/FAV) Mandrin a pointe central escamotable - M16 (x artt. FA/FAV)	
<b>Art. CVG12</b>	Convogliatore d'acqua completo di tanica Wasserleitelement komplett mit Kanister Asperseur d'eau avec réservoir	
<b>Art. VTKIT</b>	Ventose per foratura con acqua (Ø 40mm + Ø 60mm) Saugnäpfe für die Bohrung mit Wasser (Ø 40mm + Ø 60mm) Ventouses pour perçage avec eau (Ø 40mm + Ø 60mm)	
<b>Art. 89</b>	Riduzione M16 - G 1/2" Adapter M16 - G 1/2" Adaptateur M16 - G 1/2"	

## GUIDA ALLA SCELTA DI FRESE E PUNTE DIAMANTATE

### ANLEITUNG ZUR AUSWAHL DER DIAMANTKRONEN • GUIDE POUR LA SÉLECTION DES FRAISES DIAMANTEES

	MOD.	UTILIZZO / VERWENDEN / UTILISATION
mm <i>inch</i>		
4 <i>5/32</i>	FAJ	tasselli / Wanddübel / fiches murales
5 <i>3/16</i>	FAJ / FTJ / MU	tasselli / Wanddübel / fiches murales
6 <i>1/4</i>	FAJ / FS / FTJ / FT-S / MU	tasselli / Wanddübel / fiches murales
8 <i>5/16</i>	FAJ / FS / FTJ / FT-S / MU	tasselli / Wanddübel / fiches murales
10 <i>3/8</i>	FAJ / FS / FTJ / FT-S / FT / MU	tasselli / Wanddübel / fiches murales
12 <i>1/2</i>	FAJ / FS / FTJ / FT-S / MU	tasselli, fermaporta / Wanddübel, Türstopper / fiches murales, arrêt de porte
14 <i>9/16</i>	FS / MU	tasselli, fermaporta / Wanddübel, Türstopper / fiches murales, arrêt de porte
15 <i>5/8</i>	FT / FT-S	tubo 1/4", tasselli, fermaporta / 1/4"-Rohr, Wanddübel, Türstopper / Tube de 1/4, fiches murales, arrêt de porte
16 <i>5/8</i>	FS	incasso porte blindate / gepanzerte Nischentüren / porte blindée encastrée
18 <i>11/16</i>	FS	tubo 3/8" in rame per gas, acqua / 3/8"-Kupferrohr für Gas, Wasser / Tuyau en cuivre de 3/8" pour le gaz, l'eau
20 <i>3/4</i>	FA / FS / FT / FT-S / FAV	tubo 3/8" in rame per gas, acqua / 3/8"-Kupferrohr für Gas, Wasser / Tuyau en cuivre de 3/8" pour le gaz, l'eau
25 <i>1</i>	FS / FT-S	tubo 1/2" acqua, rubinetti, riscaldamento, civile / 1/2" Wasserleitung, Wasserhähne, Heizung, Zivil / Tuyau d'eau 1/2", robinets, chauffage, civil
27 <i>1-1/16</i>	FA / FS / FT / FT-S / FAV	tubo 1/2" acqua, rubinetti, riscaldamento, civile / 1/2" Wasserleitung, Wasserhähne, Heizung, Zivil / Tuyau d'eau 1/2", robinets, chauffage, civil
30 <i>1-3/16</i>	FA / FS / FT-S	tubo 3/4" acqua, rubinetti, riscaldamento, civile / 3/4" Wasserleitung, Wasserhähne, Heizung, Zivil / Tuyau d'eau 3/4", robinets, chauffage, civil
32 <i>1-1/4</i>	FA	tubo 3/4" acqua, rubinetti, riscaldamento, civile / 3/4" Wasserleitung, Wasserhähne, Heizung, Zivil / Tuyau d'eau 3/4", robinets, chauffage, civil
35 <i>1-3/8</i>	FA / FS / FT / FT-S	tubo 1" ferro o pvc per acqua, gas, industriale / 1" Eisen- oder PVC-Rohr für Wasser, Gas, Industrie / Tube 1" en fer ou en pvc pour l'eau, le gaz, l'industrie
40 <i>1-1/2</i>	FA / FS / FT / FT-S	tubo 1" ferro o pvc per acqua, gas, industriale / 1" Eisen- oder PVC-Rohr für Wasser, Gas, Industrie / Tube 1" en fer ou en pvc pour l'eau, le gaz, l'industrie
43 <i>1-11/16</i>	FT-S	tubo 1-1/4" scarico lavello, lavandino, lavastoviglie / 1-1/4" Abflussrohr Spüle, Waschbecken, Geschirrspüler / 1-1/4" tuyau d'évacuation évier, évier, lave-vaisselle
45 <i>1-3/4</i>	FA / FS	tubo 1-1/4" scarico lavello, lavandino, lavastoviglie / 1-1/4" Abflussrohr Spüle, Waschbecken, Geschirrspüler / 1-1/4" tuyau d'évacuation évier, évier, lave-vaisselle
50 <i>2</i>	FA / FS / FT / FT-S / FAV	tubo 1-1/4" scarico lavello, lavandino, lavastoviglie / 1-1/4" Abflussrohr Spüle, Waschbecken, Geschirrspüler / 1-1/4" tuyau d'évacuation évier, évier, lave-vaisselle
55 <i>2-3/16</i>	FA / FS / FT-S	tubo 1-1/2" scarico lavatrice / 1-1/2" Waschmaschinenabflussrohr / Tuyau d'évacuation de machine à laver 1-1/2"
60 <i>2-3/8</i>	FA / FS / FT / FT-S	tubo 1-1/2" scarico lavatrice / 1-1/2" Waschmaschinenabflussrohr / Tuyau d'évacuation de machine à laver 1-1/2"
65 <i>2-1/2</i>	FA / FS / FT / FT-S / FAV	tubo 1-1/2" scarico lavatrice / 1-1/2" Waschmaschinenabflussrohr / Tuyau d'évacuation de machine à laver 1-1/2"
68 <i>2-11/16</i>	FS	faretti ad incasso, tubo 2" / Einbaustrahler, 2" Rohr / spots encastrés, tube 2"
70 <i>2-3/4</i>	FA / FS / FT-S	tubo 2" scarico lavatrici industriali, raccordi pvc, piscine / 2" Abflussrohr für industrielle Waschmaschinen, PVC-Armaturen, Schwimmbäder / 2" tuyau d'évacuation machines à laver industrielles, raccords pvc, piscines
75 <i>3</i>	FA / FS / FT	tubo 2" o 2-1/2" scarico lavatrici industriali, raccordi pvc, piscine / 2"- oder 2-1/2"-Rohrabfluss für industrielle Waschmaschinen, PVC-Armaturen, Schwimmbecken / 2" ou 2-1/2" tuyau d'évacuation machines à laver industrielles, raccords pvc, piscines
100 <i>4</i>	FA / FS / FT / FT-S	tubo 3" scarico wc, presa aria cucina - caldaia / 3"-WC-Abflussrohr, Küchenluftansaugung - Kessel / tuyau d'évacuation des toilettes de 3", prise d'air de la cuisine - chaudière
120 <i>4-3/4</i>	FA / FS / FT / FT-S	presa aria cucina - caldaia / Küchenluftansaugung - Kessel / prise d'air de la cuisine - chaudière

Lavorazioni speciali  
*Besondere Bearbeitungen*  
*Travaux spéciaux*

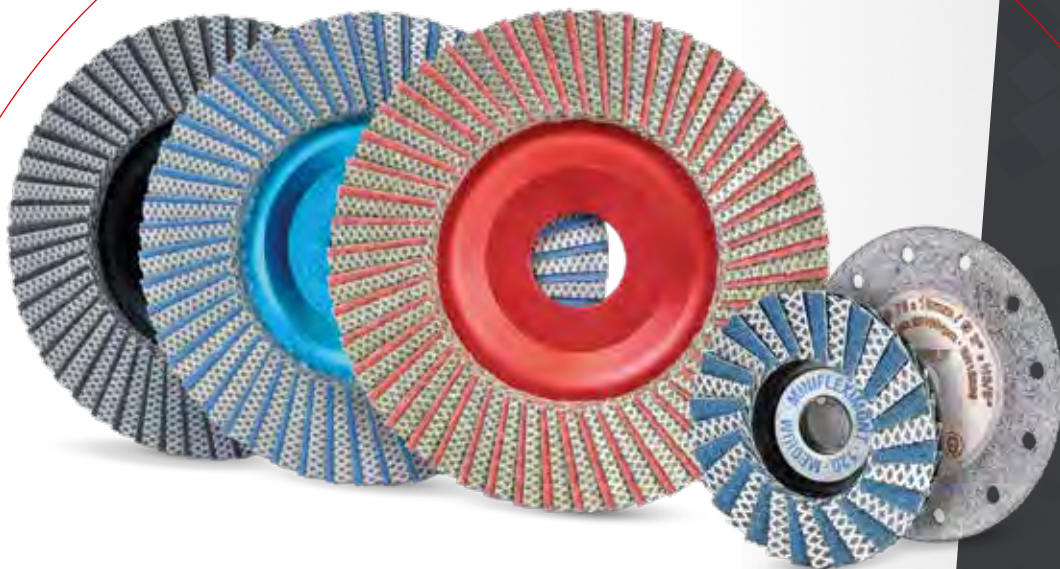

# FPUBH - MONDRILLO

**NEW**

IT Fresa diamantata universale per allargare e sagomare i fori.  
 DE Universal Diamant-Fräsfinger für das Vergrößern und Ausformen von Löchern.  
 FR Fraise diamantée universelle pour agrandir et façonner un trou.



Art.	Ø		M14*	max mm
	mm	inch		
FPUBH6	6	1/4	M14*	35
FPUBH20	20	3/4	M14*	50

\* 5/8 inch: A richiesta • Auf Anfrage • Sur demande

Gres porcellanato/Ceramica/Granito/Marmo/Vetro  
 Feinsteinzeug/Keramik/Granit/Marmor/Glas  
 Grés Vittrifié/Cèramique/Granit/Marbre/Verre



# FPSBH - MONDRILLO

**NEW**

IT Frese coniche diamantate a profilo svasatore per la rifinitura dei fori.  
 DE Diamantfräser mit Ansenkprofil zum bearbeiten der Loecher.  
 FR Fraises coniques diamantées à profil évasé pour la finition des trous.

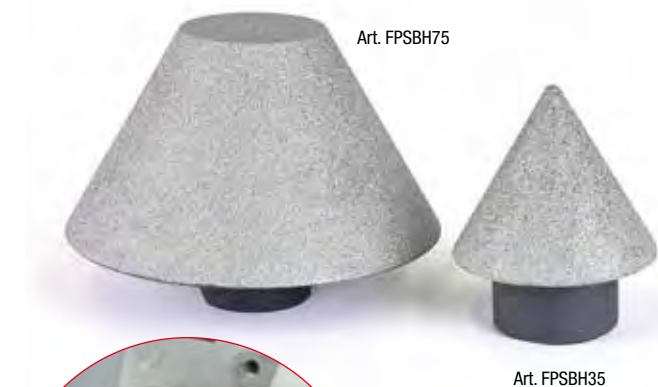

Art.	Ø		M14*
	mm	inch	
FPSBH35	5 ÷ 35	3/16 ÷ 1-3/8	M14*
FPSBH75	35 ÷ 75	1-3/8 ÷ 3	M14*

\* 5/8 inch: A richiesta • Auf Anfrage • Sur demande

Gres porcellanato/Ceramica/Granito/Marmo/Vetro  
 Feinsteinzeug/Keramik/Granit/Marmor/Glas  
 Grés Vittrifié/Cèramique/Granit/Marbre/Verre

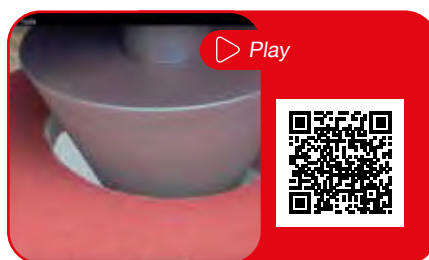

# FP-PI - MONDRILLO

IT Mola diamantata per "pietta lavabo".  
 DE Diamant-Schleiftopf für "Spülbeckenablauf".  
 FR Meule diamantée pour "bonde de lavabo".

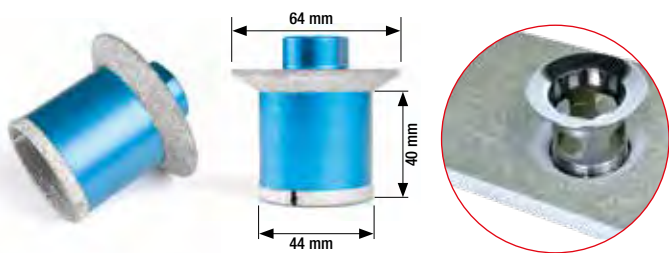

Art.	M14 *	
FP-PI		

\* 5/8 inch: A richiesta • Auf Anfrage • Sur demande

Gres porcellanato/Granito/Marmo/Resine sintetiche  
 Feinsteinzeug/Granit/Marmor/Kunsthharze  
 Grés vitrifié/Granit/Marbre/Résines synthétiques

# AFTERCUT - MONDRILLO

IT Profilatore antirottura.  
 DE Kantenreiniger.  
 FR Profilateur anti-rotture.



Art.	M14 *	
AFTERCUT		

\* 5/8 inch: A richiesta • Auf Anfrage • Sur demande

Gres porcellanato/Ceramica  
 Feinsteinzeug/Keramik  
 Grés vitrifié/Cèramique



# MONDRILLO

IT Scontornatori diamantati  
 DE Diamant-Profilfräse  
 FR Biseautage diamante

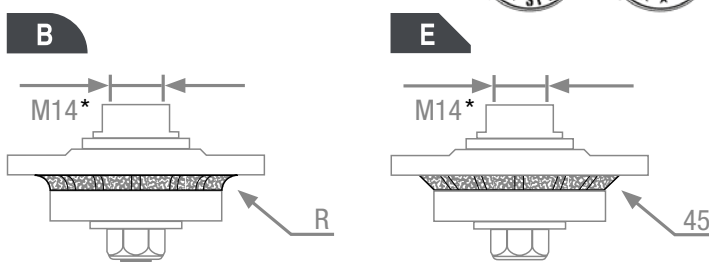

Gres porcellanato/Granito/Marmo  
 Feinsteinzeug/Granit /Marmor  
 Grés vitrifié/Granit/Marbre

Art.		Tipo / Typ / Taper
B05	Utensile completo Komplettes Werkzeug Outil complet	B = R 5mm
B10		B = R 10mm
E03		E = 45° 3mm
E05		E = 45° 5mm
B03-D	Diamante di ricambio Ersatzdiamant Diamant de remplacement	B = R 3mm
B05-D		B = R 5mm
B10-D		B = R 10mm
E03-D		E = 45° 3mm
E05-D		E = 45° 5mm

\* 5/8 inch: A richiesta • Auf Anfrage • Sur demande

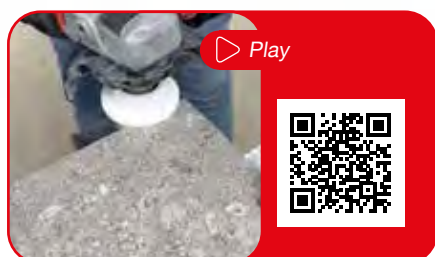

# FPV - MONDRILLO

IT Mola diamantata per profilo tipo "V".  
 DE Diamant-Schleiftopf für V-Profil.  
 FR Meule diamantée pour profil type "V".



V



Art.		
FPV22	"V" Profile - R = 22mm	M14*

\* 5/8 inch: A richiesta • Auf Anfrage • Sur demande

Gres porcellanato/Granito/Marmo  
 Feinsteinzeug/Granit /Marmor  
 Grés vitrifié/Granit/Marbre



# FP-AS - MONDRILLO

IT Mola diamantata per profilo antiscivolo.  
 DE Diamant-Schleiftopf für Rutschfreie Tritte.  
 FR Meule diamantée pour profil antidérapant.



Art.		
FP-AS	20+20mm (3/4 + 3/4")	M14*

\* 5/8 inch: A richiesta • Auf Anfrage • Sur demande

Gres porcellanato/Granito/Marmo  
 Feinsteinzeug/Granit /Marmor  
 Grés vitrifié/Granit/Marbre



# FP-GO - MONDRILLO

IT Mola diamantata per "gocciolatoio".  
 DE Diamant-Schleiftopf für "Tropfkanaele".  
 FR Meule diamantée pour "goutte pendante".



Art.		
FP-GO		M14*

\* 5/8 inch: A richiesta • Auf Anfrage • Sur demande

Gres porcellanato/Granito/Marmo  
 Feinsteinzeug/Granit /Marmor  
 Grés vitrifié/Granit/Marbre

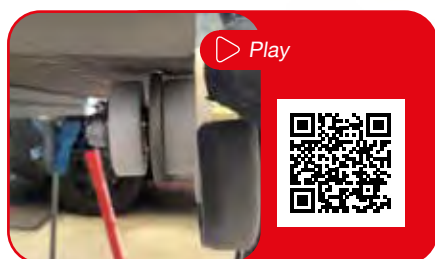

# PDR - PADS

**IT** Platorelli diamantati resinoidi con attacco velcro™ per la levigatura e lucidatura. Gres porcellanato/Granito/Marmo/Vetro.

**DE** Diamant-Harz-Schleifscheibe mit Velcro™ Auflage zum Schleifen und Polieren. Feinsteinzeug/Granit/Marmor/Glas.

**FR** Meules de résine de diamant avec fixation velcro™ pour le meulage et le polissage. Grés Vitrifié/Granit/Marbre/Verre.



Art.

PDR	M14*		
PDR 0	Step "0"		
PDR 1	Step "1"		
PDR 2	Step "2"		
PDR 3	Step "3"		
PDRKIT	Step "1 + 2 + 3"		

\* 5/8 inch: A richiesta • Auf Anfrage • Sur demande

Art. PDRKIT

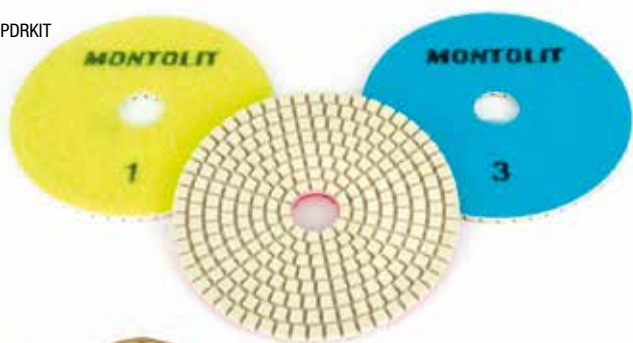

Art. PDR



Art. PDR0



# MASTERTECH

**IT** Tamponi diamantati per sgrossare e rifinire.

**DE** Diamant-Handpad zum Schleifen und Polieren.

**FR** Tampons diamantés pour degrossir et ragréer.



Art.

DT262	Blistre: 1 art. DT060 + 1 art. DT200		
DT606	Box: 6 artt. DT060 - Medium		
DT620	Box: 6 artt. DT200 - Fine		



Art. DT200 - Fine

Monocottura/Bicottura/Marmo/Vetro  
Keramikfliesen/Marmor/Glas  
Monocuisson/Faïence/Marbre/Verre



Art. DT060 - Medium

Gres porcellanato/Klinker/Granito  
Feinsteinzeug/Klinker/Granit  
Gres cerame/Klinker/Granit

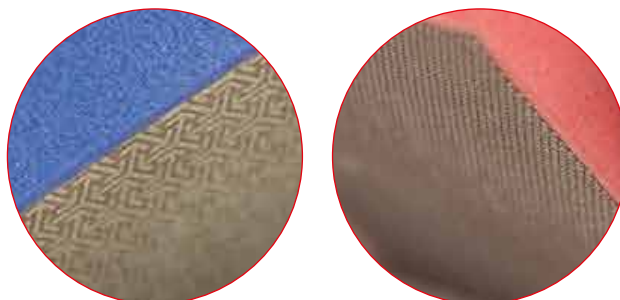

Art.

Art.	Grana / Körnung / Grain	Color		
DF60	60			
DF120	120			
DF200	200			
DF400	400			
DF500	500			
DF1500	1500			
DF3000	3000			

# STL - MONDRILLO

IT Mole diamantate per taglio e levigatura.  
 DE Diamant-Schleifscheibe zum Schneiden und Schleifen.  
 FR Meules diamantées pour découpe et ponçage.



STL125GF-M

FINE

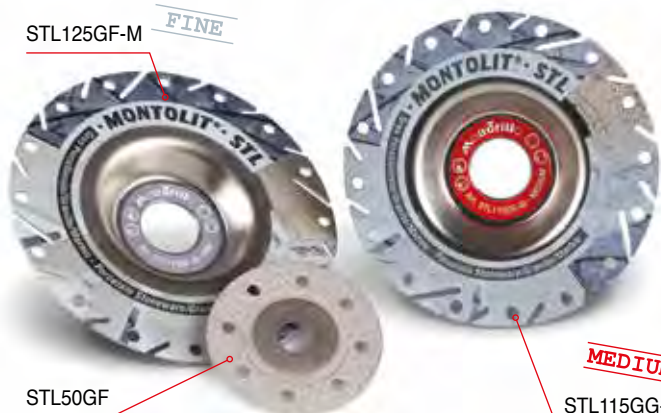

STL50GF

MEDIUM

STL115GG-M

Gres porcellanato/Ceramica delicata/Marmo/Vetro  
 Feinsteinzeug/Empfindliche Keramikfliesen/Marmor/Glas  
 Grés vitrifié/Céramique délicat/Marbre/Verre

FINE

Art.	Ø		Ø	
	mm	inch	mm	
STL50GF	50	2	10	
STL76GF	76	3	10	
STL115GF-M	115	4,5	22,2*	
STL125GF-M	125	5	22,2*	

\* 5/8 inch: Riduzione a richiesta • Reduzierring auf Anfrage • Réduction sur demande



Gres porcellanato/Granito/Pietra/Cemento  
 Feinsteinzeug/Granit/Stein/Beton  
 Grés vitrifié/Granit/Pierre/Béton

MEDIUM

Art.	Ø		Ø	
	mm	inch	mm *	
STL115GG-M	115	4,5	22,2	
STL125GG-M	125	5	22,2	

\* 5/8 inch: Riduzione a richiesta • Reduzierring auf Anfrage • Réduction sur demande

# MONDRILLO

IT Platorelli diamantati multiuso.  
 DE Mehrzweck Diamant-Schleifscheibe.  
 FR Meule diamantée multiusage.



FINE

Gres porcellanato/Ceramica delicata/Marmo/Vetro  
 Feinsteinzeug/Empfindliche Keramikfliesen/Marmor/Glas  
 Grés vitrifié/Céramique délicat/Marbre/Verre

Art.	Ø		Ø	
	mm	inch	mm	
PE115GF	115	4,5	22,2 *	
PEBS115GF	115	4,5	M14	

\* 5/8 inch: Riduzione a richiesta • Reduzierring auf Anfrage • Réduction sur demande

Gres porcellanato/Granito/Pietra/Cemento/Mattoni  
 Feinsteinzeug/Granit/Stein/Beton/Mauerziegel  
 Grés vitrifié/Granit/Pierre/Béton/Briques

MEDIUM

Art.	Ø		Ø	
	mm	inch	mm	
PE115GG	115	4,5	22,2 *	
PEBS115GG	115	4,5	M14	

\* 5/8 inch: Riduzione a richiesta • Reduzierring auf Anfrage • Réduction sur demande

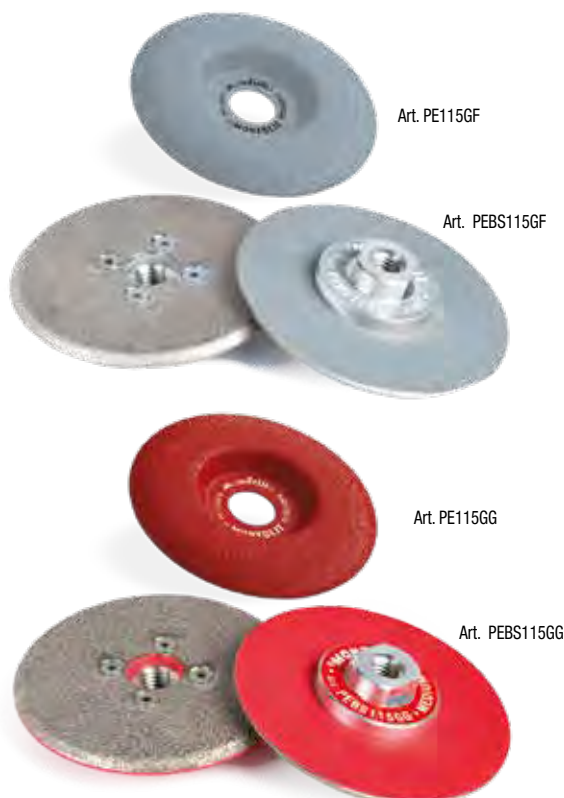

Art. PE115GF

Art. PEBS115GF

Art. PE115GG

Art. PEBS115GG

# FLEXIMONT

**NEW**

IT Dischi diamantati lamellari.  
 DE Lamellar Diamantscheiben.  
 FR Disques diamantés lamellaire.

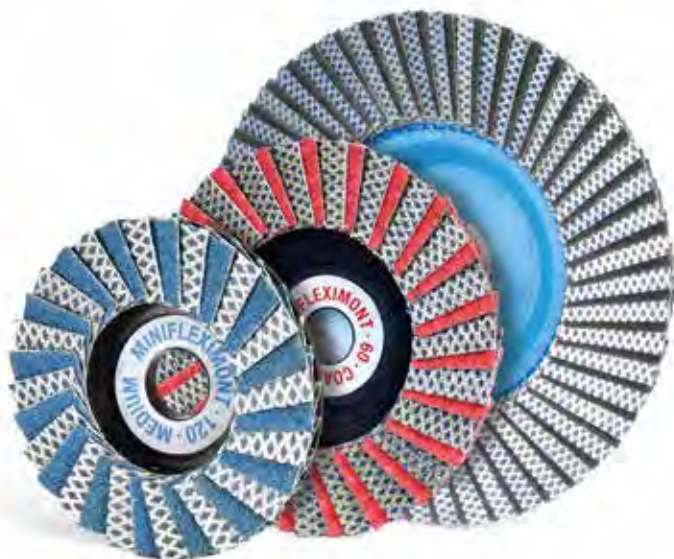

Art.	Grana / Körnung / Grain	Ø		Ø
		mm	inch	mm
<b>NEW</b> MINIFLEXIMONT-GG	grossa / grob / grossier	50	2	10
<b>NEW</b> MINIFLEXIMONT-GM	media / mittel / moyen	50	2	10
<b>NEW</b> MIDIFLEXIMONT-GG	grossa / grob / grossier	76	3	10
<b>NEW</b> MIDIFLEXIMONT-GM	media / mittel / moyen	76	3	10
FLEXIMONTGG	grossa / grob / grossier	115	4,5	22,2*
FLEXIMONTGM	media / mittel / moyen	115	4,5	22,2*
FLEXIMONTGF	fine / fein / fin	115	4,5	22,2*

\* 5/8 inch: Riduzione a richiesta • Reduzierring auf Anfrage • Réduction sur demande

Gres porcellanato/Ceramica/Granito/Marmo/Vetro  
 Feinsteinzeug/Keramikfliesen/Granite/Marmor/Glas  
 Grés vitrifié/Cèramique/Granit/Marbre/Verre



pg. 107 → Espositore  
 Ausstellmodul  
 Affichage



# FLEXIMONT - Super Aluminium

IT Dischi diamantati lamellari.  
 DE Lamellar Diamantscheiben.  
 FR Disques diamantés lamellaire.



Corpo in alluminio  
 Aluminium-Körper  
 Corps en aluminium

Art.	Grana / Körnung / Grain	Ø		Ø
		mm	inch	mm *
FLEXIMONT-S-GG	grossa / grob / grossier	115	4,5	22,2
FLEXIMONT-S-GM	media / mittel / moyen	115	4,5	22,2
FLEXIMONT-S-GF	fine / fein / fin	115	4,5	22,2

\* 5/8 inch: Riduzione a richiesta • Reduzierring auf Anfrage • Réduction sur demande

Gres porcellanato/Ceramica/Granito/Marmo/Vetro  
 Feinsteinzeug/Keramikfliesen/Granite/Marmor/Glas  
 Grés vitrifié/Cèramique/Granit/Marbre/Verre

# PEM - MONDRILLO

IT Platorello per rimozione colla ed epossidico.  
 DE Schleifteller für Kleber und Epoxydharz  
 FR Disques diamantés lamellaire.



Art.				
	mm	inch	mm*	
PEM115	115	4,5	22,2	
PEM125	125	5	22,2	

\* 5/8 inch: Riduzione a richiesta • Reduzierring auf Anfrage • Réduction sur demande

Adesivo/Colla/Epossidico/Guaina/Intonaci/Resine  
 Kleber/Epoxidharz/Putze/Harze  
 Adhésif/Colle/Résine Epoxy/Gaines/Enduits/Résines



Adattatore 22,2mm / M14  
 Adapter 22,2mm / M14  
 Adaptateur 22,2mm / M14

Art. AUM14

# PLUME

IT Mola diamantata sinterizzata per levigatura.  
 DE Gesinterter Diamant-Schleiftopf.  
 FR Meule diamantée sinterisée pour ponçage.



Speciale per macchine a batteria  
 Speziell für batteriebetriebene Maschinen  
 Spécial pour les machines à batterie



Art.						
	mm	inch	mm*	g		
PLUME100	100	4	M14	144		
PLUME125	125	5	M14	216		

\* 5/8 inch: Riduzione a richiesta • Reduzierring auf Anfrage • Réduction sur demande

Edilizia/Gres Porcellanato/Granito  
 Bau/Feinsteinzeug/Granit  
 Batiment/Grès Vitrifié/Granit



Corpo in polimero ultraleggero  
 Ultraleichter Polymer-Körper  
 Corps ultra-léger en polymère

# TRITONE

IT Mola diamantata sinterizzata per levigatura.  
 DE Gesinterter Diamant-Schleiftopf.  
 FR Meule diamantée sinterisée pour ponçage.



Art.	Ø		mm
	mm	inch	
TRITONE100	100	4	M14
TRITONE115	115	4,5	22,2 *
TRITONE125	125	5	22,2 *
TRITONE150	150	6	22,2 *
TRITONE180	180	7	22,2 *

\* 5/8 inch: Riduzione a richiesta • Reduzierring auf Anfrage • Réduction sur demande

Calcestruzzo/Materiali lapidei/Gres porcellanato/Rimozione colla e epossidico  
 Beton/Steinmaterial/Feinsteinzeug/Kleber- und Epoxidentfernung  
 Béton/Matériel de pierre/Grés vitrifié/Enlèvement de colle et d'époxy



Adattatore 22,2mm / M14  
 Adapter 22,2mm / M14  
 Adaptateur 22,2mm / M14

Art. AUM14



# VORTEX

IT Platorello universale scheletrato.  
 DE Universal Schleifteller.  
 FR Meule universel.



Art.	Ø		mm
	mm	inch	
PUSV125	125	5	22,2 *
PUSV150	150	6	22,2 *
PUSV180	180	7	22,2 *

\* 5/8 inch: Riduzione a richiesta • Reduzierring auf Anfrage • Réduction sur demande

Calcestruzzo/Materiali lapidei  
 Beton/Stein  
 Béton/Matériel de pierre



Adattatore 22,2mm / M14  
 Adapter 22,2mm / M14  
 Adaptateur 22,2mm / M14

Art. AUM14

# TURBO

IT Mole diamantate per levigatura.  
 DE Diamant-Topfschleifscheibe.  
 FR Meule diamantée pour ponçage.



Art.	Ø		Ø	
	mm	inch	mm	
PUT115	115	4,5	22,2 *	
PUT125	125	5	22,2 *	

\* 5/8 inch: Riduzione a richiesta • Reduzierring auf Anfrage • Réduction sur demande

Granito/Calcestruzzo - Granit/Beton - Granit/Béton

Art. AUM14



Adattatore 22,2mm / M14  
 Adapter 22,2mm / M14  
 Adaptateur 22,2mm / M14

# SECTOR

IT Mole diamantate per levigatura.  
 DE Diamant-Topfschleifscheibe.  
 FR Meule diamantée pour ponçage.



Art.	Ø		Ø	
	mm	inch	mm	
PUSC100M14	100	4	M14	
PUSC115	115	4,5	22,2 *	
PUSC125	125	5	22,2 *	
PUSC150	150	6	22,2 *	
PUSC180	180	7	22,2 *	

\* 5/8 inch: Riduzione a richiesta • Reduzierring auf Anfrage • Réduction sur demande

Calcestruzzo/Materiali lapidei - Beton/Steinmaterial  
 Béton/Matériau de pierre

Art. AUM14



Adattatore 22,2mm / M14  
 Adapter 22,2mm / M14  
 Adaptateur 22,2mm / M14

# SECTOR

IT Mole diamantate per levigatura.  
 DE Diamant-Topfschleifscheibe.  
 FR Meule diamantée pour ponçage.



Art.	Ø		Ø	
	mm	inch	mm	
PUSA115	115	4,5	22,2 *	
PUSA125	125	5	22,2 *	
PUSA180	180	7	22,2 *	

\* 5/8 inch: Riduzione a richiesta • Reduzierring auf Anfrage • Réduction sur demande

Materiali abrasivi - Abrasive Oberflächen - Matériaux abrasifs

Art. AUM14



Adattatore 22,2mm / M14  
 Adapter 22,2mm / M14  
 Adaptateur 22,2mm / M14

# DISPLAY

Art. 400FL3



pg. 28 → Prodotto  
Produkt  
Produit

Art. 400FUXT



pg. 68 → Prodotto  
Produkt  
Produit

Art. 400SMALL



pg. 72 → Prodotto  
Produkt  
Produit



Art. 400FAST



pg. 75 → Prodotto  
Produkt  
Produit



Art. 400FAJEX



pg. 87 → Prodotto  
Produkt  
Produit

Art. 400FT-S



pg. 91 → Prodotto  
Produkt  
Produit

Art. 400FLEXI



pg. 103 → Prodotto  
Produkt  
Produit

# TOTEM

IT Espositori  
DE Aussteller  
FR Présentoirs



Art. 960DM

Art. 960M

Art. 960S



Art. 960G



Art.

960M	Expo macchine ed utensili - <i>Aussteller für Maschinen und Werkzeuge</i> - <i>Présentoirs de machines et d'outils</i>	104x45x234 cm - 40x18x92-1/8"
960DM	Expo utensili diamantati - <i>Aussteller für Diamantwerkzeuge</i> - <i>Présentoirs de outils diamantés</i>	104x45x234 cm - 40x18x92-1/8"
960S	Serrature di sicurezza - <i>Sicherheitsschlösser</i> - <i>Serrures de sécurité</i>	set 30 pcs.
960G	Ganci doppi per pannello forato - <i>Doppelhaken für perforierte Platten</i> - <i>Double crochet pour panneau perforé</i>	set 10 pcs.

# TOTEM MASTERPIUMA

IT Espositore Masterpiuma  
DE Masterpiuma Display-Ständer  
FR Présentoir Masterpiuma

Art.

960MP (79x60x203h cm - 31x23,5x78 inch)



# SYMBOLOGIA • SYMBOLIK • SYMBOLOGIE

	Lunghezza massima di taglio <i>Schnittlänge</i> <i>Longueur maximum de coupe</i>		Lunghezza di taglio in diagonale <i>Schnittlänge diagonal</i> <i>Longueur de coupe en diagonale</i>		Spessore massimo di taglio <i>Schnittiefe</i> <i>Epaisseur maximum de coupe</i>		Potenza di spacco <i>Kraft</i> <i>Puissance de rupture</i>		Peso <i>Gewicht</i> <i>Poids</i>		Diametro fresa <i>Durchmesser Fräser</i> <i>Diamètre du fraise</i>		Diametro e foro disco <i>Durchmesser Scheibe und Bohrung</i> <i>Diamètre et trou du disque</i>		Attacco mola/platello <i>Anschluss für Schleifscheibe</i> <i>Connexion pour meule</i>		Non ammesso l'uso della percussione <i>Schlagbohrmaschine ist nicht zulässig</i> <i>L'emploi de la percussion n'est pas autorisé</i>		Numero di segmenti <i>Quantité des segments</i> <i>Segmentzahl</i>		Spessore del disco <i>Dicke der Scheibe</i> <i>Epaisseur du disque</i>		Imballo / Verpackung / Emballage	Unità <i>Einheit</i> <i>Unité</i>																											
	Attacco fresa <i>Anschluss für Fräser</i> <i>Connexion pour fraise</i>		Attacco fresa <i>Anschluss für Fräser</i> <i>Connexion pour fraise</i>		Attacco fresa <i>Anschluss für Fräser</i> <i>Connexion pour fraise</i>		Dimensioni <i>Abmessungen</i> <i>Dimensions</i>		Altezza <i>Höhe</i> <i>Hauteur</i>		Tipo o numero batterie <i>Typ oder Anzahl der Batterien</i> <i>Type ou numéro de batterie</i>		Tempi di ricarica batterie <i>Akku-Ladezeiten</i> <i>Temps de charge de la batterie</i>		Connettore USB <i>USB-Connector</i> <i>Connecteur USB</i>		Portata <i>Belastung</i> <i>Charge</i>		Non ammesso l'uso a secco <i>Der Trockenschnitt ist nicht zulässig</i> <i>L'emploi à sec n'est pas autorisé</i>		Utilizzo a secco <i>Trockenschnitt</i> <i>Utilisation à sec</i>		Utilizzo a secco con aspirazione <i>Trockenschnitt mit Saugvorrichtung</i> <i>Utilisation à sec avec aspiration</i>		Utilizzo ad umido <i>Naßschnitt</i> <i>Utilisation à eau</i>		Potenza motore <i>Motorleistung</i> <i>Puissance du moteur</i>		Smerigliatrice angolare <i>Winkelschleifmaschine</i> <i>Ponceuses angulaires</i>		Scanalatore <i>Mauernutfräse</i> <i>Rainureuse</i>		Taglierina elettrica ad acqua <i>Elektrische Schneidemaschinen mit Wasserkühlung</i> <i>Découpeuse électrique à eau</i>		Taglierina elettrica ad acqua <i>Elektrische Schneidemaschinen mit Wasserkühlung</i> <i>Découpeuse électrique à eau</i>		Taglierina da cantiere <i>Tischsäge für Baustellen</i> <i>Tronçonneuse sur table</i>		Troncatura <i>Trennschneider</i> <i>Tronçonneuse</i>		Taglia pavimenti <i>Fugenschneider</i> <i>Scie à sol</i>		Sistema motorizzato MOTOFLASH <i>Motorbetriebenes System MOTOFLASH</i> <i>Système motorisé MOTOFLASH</i>		Elettroforatrice ad acqua <i>Elektrobohrmaschine mit Wasserkühlung</i> <i>Perceuse électrique à eau</i>		Trapano/Carotatrice manuale <i>Bohrmaschine</i> <i>Perceuse électrique portative</i>		Trapano a batteria <i>Akku-Bohrschrauber</i> <i>Perceuse sans fil</i>		Carotatrice professionale a telaio <i>Professionelle Kernbohrmaschine mit Rahmen</i> <i>Machine professionnelle de carottage avec cadre</i>
<p>B = Blister C = Cartone/Karton/ Carton S = Scatola/Schachtel/Boîte T = Sacchetto/Beutel/Sachet V = Non imballato/Nicht verpackt/Pas emballé</p>		1	2	3	...	...																																													



## montolit.com

Registrati sul nostro sito per ricevere news, informazioni tecniche e promozioni su tutti i nostri prodotti.

Melden Sie sich auf unserer Webseite an, um Neuigkeiten, technische Informationen und Aktionen von allen unseren Produkten zu erhalten.

Souscrire sur notre site internet pour recevoir informations et promotions sur tous nos produits.

## GARANZIA

**MACCHINE ED ATTREZZATURE:** per tutte le attrezzature MONTOLIT é riconosciuta una garanzia di 2 (due) anni a partire dalla data di vendita (fattura / bolla di consegna / scontrino fiscale). Tagliapiastre, forapiastre, tranciblocchi e tagliategole manuali sono coperti da garanzia a vita su eventuali difetti di costruzione (riconosciuti a giudizio esclusivo dell'Ufficio Tecnico della Brevetti MONTOLIT S.p.A.). Guasti derivanti da un uso non conforme o da normale usura sono esclusi dalle presenti garanzie.

**UTENSILI DIAMANTATI:** viene riconosciuta totalmente, a giudizio dell'Ufficio Tecnico della Brevetti MONTOLIT S.p.A., su dischi appena usati e non ancora consumati che presentino evidenti difetti di fabbricazione. La garanzia non verrà riconosciuta per i dischi deteriorati in seguito al loro uso per tagli di materiali diversi da quelli per i quali sono stati specificatamente prodotti. Reclami riguardanti qualsiasi disco da taglio consegnato saranno accettati solamente se il consumo dell'altezza della fascia diamantata non abbia superato il 20%.

Da sempre, la Brevetti MONTOLIT impiega e fornisce materiali di prima scelta. Si tratta di un impegno di serietà e moralità commerciale che eleva la Nostra Azienda al di sopra dello standard. Sicurezza e garanzia del prodotto costituiscono per noi motivo di vanto. Una realtà operativa che non è fatta solo di parole, ma anche di vere e proprie garanzie scritte. Infatti assicuriamo tutti i nostri prodotti contro i danni involontariamente cagionati in conseguenza di un fatto accidentale verificatosi per difetto di costruzione e fabbricazione del prodotto anche dopo la sua consegna e commercializzazione.

## GARANTIE

**MASCHINEN UND AUSTRÜSTUNGEN:** für alle Ausrüstungen von MONTOLIT wird eine Garantie von 2 (zwei) Jahren ab Verkaufsdatum (Rechnung / Lieferschein / Kassenzettel) gewährt. Eventuelle Fabrikationsfehler der Fliesenscheider, Fliesen-Lochscheider, Blockscheider und manuellen Ziegelschneidmaschinen sind mit einer (nach unanfechtbarem Ermessen des Technischen Büros der Firma Brevetti MONTOLIT S.p.A. anerkannten) Garantie auf Lebenszeit gedeckt. Durch unsachgemäße Benutzung oder normalen Verschleiß verursachte Schäden sind von diesen Garantieleistungen ausgeschlossen.

**DIAMANTWERKZEUGE:** wenig verwendete und noch nicht verschlissene Scheiben, die offensichtliche Fabrikationsfehler haben werden nach Ermessen der Technischen Abteilung der Firma Brevetti MONTOLIT S.p.A. völlig ersetzt. Scheiben, die beschädigt worden sind, weil sie für nicht geeignete Materialien verwendet wurden, werden nicht ersetzt. Beanstandungen von gelieferten Diamant-Trennscheiben können nur bis zu einem Verbrauch von 20% der Belag- bzw. Segmenthöhe angenommen werden.

Das Unternehmen Brevetti MONTOLIT fühlt sich dem hohen Qualitätsanspruch seiner Kunden stets verpflichtet. Aus diesem Grunde verwenden und liefern wir seit jeher nur Erzeugnisse von ausgezeichneter Qualität. Unsere Geschäftspraxis beruht jedoch nicht nur auf Worten, sondern stützt sich auf eindeutige schriftliche Garantien. Unsere Erzeugnisse sind gegen unwillkürliche verursachte Schäden versichert, die durch einen Konstruktionsfehler entstanden sind. Dies gilt auch nach Lieferung und Verkauf.

## GARANTIE

**MACHINES ET OUTILLAGE:** une garantie de 2 (deux) ans à compter de la date de vente (facture/bulletin de livraison/reçu fiscal) s'applique à tous les équipements MONTOLIT. Les machines manuelles à couper les carreaux, à percer les carreaux, à couper les blocs et les tuiles bénéficient d'une garantie à vie sur les défauts éventuels de construction (reconnue par un jugement sans appel du Service Technique de "Brevetti MONTOLIT S.p.A."). Les pannes qui dériveraient d'un usage non conforme ou d'une usure normale sont exclues de ces garanties.

**OUTILS DIAMANTES:** la garantie joue totalement suivant l'avis du Bureau Technique de la Brevetti MONTOLIT S.p.A. pour les disques venant d'être utilisés et ne pas détériorés, qui présentent des défauts de fabrication. Cette garantie ne joue d'avantage pour des disques détériorés suivant la coupe de matériaux différents à ceux pour lesquels ils ont été produits. Les réclamations peuvent être traitées uniquement lorsque l'usure de la jante diamantée ne dépasse pas le 20%.

Depuis toujours Brevetti MONTOLIT utilise et fournit du matériel d'excellente qualité. Notre entreprise est caractérisée par un sérieux professionnel et commercial qui va bien au-delà des standards. En effet, la sécurité et la garantie du produit font notre orgueil. Mais nous ne nous arrêtons pas aux mots car nous offrons à notre clientèle des garanties écrites: nous assurons tous nos produits contre tout dommage accidentel pouvant résulter d'un défaut de construction et fabrication même après la livraison et la commercialisation.

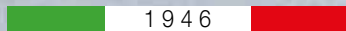

## Brevetti Montolit S.p.A.

Sedi operative | Hauptsitz des Unternehmens | Siège de l'entreprise:

Largo Cav. Montoli - 21050 Cantello (VA) Italy

Via Varese 4/A - 21050 Cantello (VA) Italy

Sede legale | Juristischer Hauptsitz | Siège légal:

Via Turconi, 25 - 21050 Cantello (VA) Italy

Tel. ++39 0332 419 211

info@montolit.com

## SERVIZIO CLIENTI / CUSTOMER SERVICE



service@montolit.com

Per consigli e soluzioni tecniche  
Für Beratung und technische Lösungen  
Pour des conseils et des solutions techniques

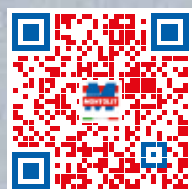

montolit.com



Associata con: | Assoziiert mit: | Associé à:



CONFINDUSTRIA  
Varese

Montolit è partner tecnico delle seguenti scuole e associazioni:  
Montolit ist ein technischer Partner der folgenden Schulen und Verbände:  
Montolit est un partenaire technique des écoles et associations suivantes:

Rivenditore autorizzato  
Autorisierter Händler  
Distributeur autorisé:

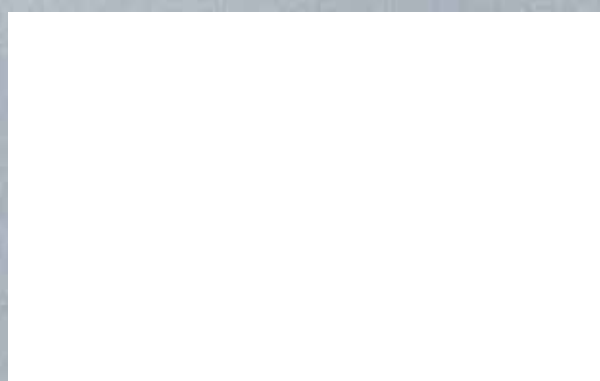

Descrizioni ed illustrazioni si intendono fornite a semplice titolo indicativo. La Casa si riserva il diritto, ferme restando le caratteristiche essenziali dei modelli qui descritti ed illustrati, di apportare ai propri prodotti, in qualunque momento, e senza preavviso, le eventuali modifiche da essa ritenute necessarie a scopo di miglioramento o per qualsiasi esigenza di carattere costruttivo o commerciale.

Abbildungen und Beschreibungen sind nicht verbindlich. Die Firma MONTOLIT behält sich das Recht vor, zu jeder Zeit und ohne Voranmeldung Änderungen, und Besserungen der Produkte vorzunehmen, sowohl in technischer als auch in kommerzieller Hinsicht.

Toutes les descriptions et illustrations sont fournies à titre indicatif. Etant entendues les données essentielles des modèles ci décrits et illustrés, la Société se réserve le droit de modifier les produits toutes les fois et sans préavis au but de leur amélioration ou du point de vue constructif et de la commercialisation.